

EDGE WASTEWATER

STANDARD TECHNICAL SPECIFICATIONS for DECENTRALIZED WASTEWATER SYSTEMS

Version 1.0

February 18, 2026



Utility Approval

Matthew 2/26/2026

Date

EDGE WASTEWATER
410 New Salem Hwy.
Suite 100
Murfreesboro, TN 37129

By

SEC Inc.

SEC No. 25102

INDEX

<u>SECTION</u>	<u>TITLE (General Content)</u>
01 11 00	SUMMARY OF WORK
01 33 16	DESIGN REQUIREMENTS (effluent collection, effluent treatment, control building, soil mapping, effluent drip dispersal)
13 15 16	CONTROL BUILDING (Masonry, UV disinfection, Arkal filter, control panels)
22 13 13	EFFLUENT COLLECTION SYSTEM (sewer gravity mains, forcemains, & services)
22 13 43	EFFLUENT PUMPS (effluent filters, discharge assemblies, mercury switch floats, pumps, control panels, pumps stations)
22 13 53	EFFLUENT TANKS (septic and dosing tanks)
26 05 26	GROUNDING AND BONDING FOR ELECTRICAL SYSTEMS
26 20 00	ELECTRICAL WORK, GENERAL
31 10 00	SITE CLEARING (removing or protecting existing vegetation, clear & grub, stockpiling topsoil, temporary erosion and sediment control)
31 20 00	EARTH MOVING (excavating and filling, subgrade preparation, bedding course, trenching, compaction, proof rolling, blasting, unsuitable material, suitable material, general excavation, unauthorized excavation, storage of materials, backfill, trench backfill, surplus materials)
32 31 13	FENCING
32 84 13	EFFLUENT DRIP DISPERSAL (piping, encasement, valves, PRV's, control valves, drain valves, couplers, drip irrigation specialties, controllers, boxes for control valves, dispersal area)
46 07 53	BIOCLERE TREATMENT SYSTEMS
46 07 54	MOVING BED BIOFILM REACTOR TREATMENT SYSTEMS (MBBR systems)
APPENDIX	STANDARD DETAILS for DECENTRALIZED WASTEWATER SYSTEMS

END OF SECTION

SEPTIC TANK EFFLUENT COLLECTION, TREATMENT, AND DISPERSAL

A. SCOPE OF WORK

1. SCOPE

- a. This project shall consist of furnishing all material, equipment, machinery, labor, etc., necessary for the construction of the septic tank effluent collection, treatment, and dispersal facilities more particularly described on the Plans and in these Specifications. Work shall include all necessary items of construction and equipment within the limits shown on the Plans in order to provide finished installations complete in every respect in accordance with the plans and specifications.
- b. CONTRACTOR shall maintain a stamped approved set of construction plans and specifications from EDGE WASTEWATER (EDGE) and the Tennessee Department of Environment and Conservation (TDEC) on site while construction is in progress.
- c. Prior to start of construction, a pre-construction conference will be held at the Project site on a date set by EDGE.

2. TERMS

- a. The word "OWNER" shall refer to EDGE WASTEWATER or its representative.
- b. The word "CONTRACTOR" shall mean the person, partnership or corporation entering into a contract for the performance of work or the agent appointed to act for the Contractor in the performance of the work.

B. MISCELLANEOUS REQUIREMENTS

1. CONTRACTOR'S UTILITIES

CONTRACTOR shall furnish his own utilities including electricity, water, telephone and he shall provide these during construction, start-up and testing of facilities.

2. SPECIAL EQUIPMENT REQUIRED

CONTRACTOR must provide any special equipment required during construction including pipe locators, pipe cutters, tapping machines, etc.

3. CONTRACTOR'S RESPONSIBILITY FOR EQUIPMENT, ETC.

The CONTRACTOR shall keep all equipment properly lubricated prior to formal acceptance by the EDGE, and upon acceptance shall turn over to EDGE full instructions for lubrication together with at least a two months' supply of lubricant and any grease guns or accessories required for proper lubrication.

4. SERVICES OF MANUFACTURER'S REPRESENTATIVE

The extent to which services of manufacturer's representatives will be required will be generally as follows:

- a. Manufacturer's representatives shall make one visit to the job site prior to installation of equipment to check shipment and advise the CONTRACTOR's representative, in the presence of the EDGE's Representative, concerning proper installation of the equipment.
- b. Manufacturer's representative shall make a second visit to the job site to inspect, test and adjust the installed equipment in the presence of the EDGE's representative.
- c. The services of manufacturer's representatives shall also be provided as required for investigation of difficulties or correction of defects concerning the equipment during the warranty period.

5. WARRANTY

- a. The CONTRACTOR shall guarantee all equipment and work for a period of one (1) year after acceptance by EDGE unless extended in the following Specifications. EDGE reserves the right to negotiate directly with sub-contractors, equipment suppliers and others concerning warranty matters.

C. WORK COMPLETION

1. CLEAN-UP

- a. Upon completion of construction, the CONTRACTOR shall remove all boxes, forms, leftover materials, etc., and shall leave the entire area in a neat and orderly condition.

2. TESTING OF PIPING AND EQUIPMENT

- a. Before the work under this project is accepted, the CONTRACTOR must subject the various components of the system to the tests as required to prove the system. All tests must be scheduled in advance and shall be performed at a time acceptable to EDGE. The tests must be made in a manner acceptable to EDGE.
- b. All piping shall be pressure tested for a period of six (6) hours at a pressure of 150 psi. A loss of more than 5 lbs. constitutes failure. All obvious leaks shall be repaired before acceptance.
- c. All tanks, basins, sumps, or other water containing structures shall be field tested for watertightness by filling the structure and the attached riser with water to a level of two inches (2") into the riser and allowing it to stand for twenty-four (24) hours. Any drop in liquid level shall be taken as evidence of a leak and must be eliminated before acceptance.

SUMMARY OF WORK

- d. Tests of pumps, control system, meters, etc., must be made by or in the presence of the manufacturer's representative, and any defects noted shall be corrected before acceptance.
3. **START-UP**
Before acceptance of the project by EDGE, the CONTRACTOR Shall fill basins with water as necessary and perform a start-up of the system to demonstrate that all equipment and processes are functioning properly. Start-up shall be performed in the presence of EDGE.

01 11 00

SUMMARY OF WORK

END OF SECTION 01 11 00

PART 1 GENERAL

- 1.1 EDGE WASTEWATER (EDGE) has adopted the following design criteria for effluent collection, effluent treatment, and effluent dispersal. State and Local authorities having jurisdiction may have stringent design criteria. In either case, the more stringent design criteria shall be adhered to. The Developer shall submit to EDGE a topographic map showing the complete layout of the subdivision, the proposed location of the treatment facility and the drip fields (based on a NRCS soils map), and all easements. Once it is determined by EDGE, and approved in writing, that service can be provided, a detailed soils map shall be created and submitted for the areas considered for the drip field. Once approved by EDGE in writing, a detailed set of construction plans shall be submitted to EDGE for review and approval.
- 1.2 RELATED DOCUMENTS
- A. Drawings and general provisions
 - B. Specification sections:
 - 1. 13 15 16 CONTROL BUILDING
 - 2. 22 13 13 EFFLUENT COLLECTION SYSTEM
 - 3. 22 13 43 EFFLUENT PUMPS
 - 4. 22 13 53 EFFLUENT TANKS
 - 5. 32 84 13 EFFLUENT DRIP DISPERSAL
 - 7. 46 07 53 BIOCLERE TREATMENT SYSTEM
 - 8. 46 07 54 MOVING BED BIOFILM REACTOR TREATMENT SYSTEMS
- 1.3 EFFLUENT COLLECTION
- A. STEP Tank
 - 1. Pump design flow rate
 - a. The pump design flow rate shall be 300 gallons per day per residence.
 - 2. STEP tanks shall comply with Section 22 13 53 EFFLUENT TANKS.
 - 3. STEP tanks shall be as follows:
 - a. Have a minimum volume of 1,500 gallons,
 - b. Be watertight,
 - c. Be located in the front yard,
 - d. Installed after the house is constructed,
 - e. Have a high/low audible alarm, mounted on the house in plain view from the public street.
 - B. Pumping

DESIGN REQUIREMENTS

1. Effluent shall be pumped from each septic tank, through the collection system, to the treatment facility.
2. Septic tank pumps in the collection system shall act in unison to provide the following:
 - a. A collection system whose pressure will not exceed 150 psig, and
 - b. A hydraulic profile that allows each service's effluent to enter the system.
3. A design flow rate of ½ gallon per minute shall be assumed for each residential unit when pumping in unison to analyze and design the collection system.
4. Effluent pumps shall comply with Section 22 13 43
EFFLUENT PUMPS.

- C. Effluent collection line sizes shall have a minimum diameter of 3-inches.
 1. Effluent collection system shall be designed and constructed to comply with Section 22 13 13 EFFLUENT COLLECTION SYSTEM.

1.4 EFFLUENT TREATMENT

- A. Advanced Biological Treatment Systems (complying with Sections 46 07 53 or 46 07 54)

1. Design flow: 300 gallons/day/residential unit

2. Effluent Requirements:

Flow, gpd	= 300	
BOD ₅ , mg/l	= (per 1.4.A.2)	≤ 45 mg/L
TSS, mg/l	= (per 1.4.A.2)	≤ 40 mg/L
TKN, mg/l	= 50 mg/l	
Total Nitrogen, mg/l	= ≤ 10-15 mg/L	
Escherichia coli	=	94 colonies / 100 µL

3. Required Storage: Storage shall be equal to or greater than the daily design flow.
 - a. The required storage volume will be reached by the use of tanks, and the total volume in the recirculation and final disposal tanks.
 - b. Recirculation tank: Size to be determined by the number of pumps and the total storage volume required. Minimum size: 2000 gallons. Minimum number of pumps shall be 2.

DESIGN REQUIREMENTS

- c. Final disposal tank: Size to be determined by the number of pumps and the total storage volume required. Minimum size: 2000 gallons. Minimum number of pumps shall be 2
 - 5. The treatment facility control building shall be secured in a fenced area.
- 1.5 CONTROL BUILDING
- A. The Control Building shall house the ultraviolet equipment, disk filters, piping, and control panels. Building size shall be as needed with 12' x 12' minimum inside dimensions unless approved otherwise by the EDGE.
 - B. The Control Building shall comply with Section 13 15 16 CONTROL BUILDING.
 - C. Ultraviolet Disinfection
 - 1. Ultraviolet disinfection shall be used, unless otherwise approved, to disinfect the treated effluent prior to entering the disk filtration.
 - 2. Disinfection system shall have a minimum of two (2) lamps.
 - D. Filtering:
 - 1. Dual disk filters are to be used to provide filtration to the drip lines.
 - 2. Disk filter assembly is to allow back flushing the system, with return to the recirculation tank.
 - 3. Disk filters are to be sized for the design flows.
- 1.6 EFFLUENT DRIP DISPERSAL
- A. Soil Mapping
 - 1. Soil maps are to be produced by a state certified soil scientist.
 - 2. Soil maps for the drip dispersal areas are to be High Intensity Soils Map (100' Grid), unless the authority having jurisdiction requires a more intense map per their regulations.
 - 3. Useable Soils must be \geq 20-inches to the restrictive layer.
 - 4. The soils scientist must dig at least 2 test pits per soil type.
 - B. Drip Dispersal:
 - 1. Loading Rate (Land Application Rate): As determined by the soil scientist. Maximum of 0.20 gallons/square foot/day. The authority having jurisdiction may require a lower application rate per their regulations.

DESIGN REQUIREMENTS

2. Reserve area: 25%. The authority having jurisdiction may require a larger reserve area per their regulations.
 3. Drip zones:
 - a. Drip lines are to have a drip rate of 0.61 gallons per hour with drip emitters spaced at 2-feet on center.
 - b. Drip lines are to originate with the supply line and end with the return line.
 - c. Maximum length of a drip line shall be 400 feet.
 - d. Drip line spacing: Spacing of drip line to be as shown on the approved drawings.
 - e. Drip lines are to be placed 7-inches below the ground surface.
 - f. Drip lines are to run parallel to the contours and be reasonably constant in elevation.
 - g. Maximum length of drip lines per zone: to be determined by pressures @ solenoids – (typ. 4-8,000 lf per zone).
 - h. High pressure drip zones may be required to install a pressure reducing solenoid valve.
 - i. Each zone shall be the same size.
 - j. A tight line is required through unusable soils.
 - k. Typical maximum number of distal ends: 16 to 18
 - l. A solenoid valve shall be used to open and close each zone.
 - m. A flush valve is required at the high end of the zone.
 - n. There must be an even number of zones.
- C. Effluent drip dispersal design and construction shall comply with Section 32 84 13 EFFLUENT DRIP DISPERSAL.

END OF SECTION 01 33 16

PART 1 GENERAL

1.1 RELATED DOCUMENTS

- A. Drawings and general provisions
- B. Specification sections:
 - 1. 01 33 16 DESIGN REQUIREMENTS
 - 2. 22 13 43 EFFLUENT PUMPS
 - 3. 26 05 26 GROUNDING AND BONDING FOR ELECTRICAL SYSTEMS
 - 4. 31 10 00 SITE CLEARING
 - 5. 31 20 00 EARTH MOVING
 - 6. 32 84 13 EFFLUENT DRIP DISPERSAL

1.2 SUMMARY

- A. This Section includes the following:
 - 1. Products, supplies, and work necessary for building construction including concrete, masonry, wood, and finishes.
 - 2. HVAC.
 - 3. Ultraviolet disinfection and filtration.
 - 4. Cast-in-place concrete.

1.3 SCOPE

- A. Control Building shall be of suitable size to house the ultraviolet equipment, disk filters, piping, and control and electric panels. Building shall be 12' x 12' (min.) inside dimension unless approved otherwise by EDGE.
- B. This Section includes cast-in-place concrete, forms, reinforcing and other items.
- C. necessary to complete the project as indicated by the Plans unless specifically excluded.
- D. Building shall be of concrete block and brick or split faced hollow core masonry unit construction.
- E. Roof shall be gable-type with overhang and aluminum gutters.
- F. Mechanical work to be in accordance with all applicable codes and authorities. New materials to have Underwriters Labels where applicable. CONTRACTOR shall obtain all necessary permits and inspections and pay all fees included.
- G. The work shall be installed in accordance with the plans and specifications and in proper operating condition. All items shall be new, unless otherwise noted.
- H. Maintain code required clearances around all mechanical equipment.

- I. Provide a closed chamber, pressure flow ultraviolet disinfection system complete with ultraviolet lamp and power supply in a one-piece modular design.
- J. The CONTRACTOR shall provide all labor, materials, and equipment necessary to install and test the ultraviolet disinfection system in place as shown on the drawings and specified herein.

1.4 SUBMITTALS

- A. Shop drawings will be provided and shall contain, but not be limited to:
 - 1. Operation and Maintenance Manuals
 - 2. Installation Drawings
 - 3. Schematic and Wiring Diagrams
 - 4. Dimensional Drawings
 - 5. Manufacturer's Guarantee
 - 6. Recommended spare parts list
- B. Information shall be provided in sufficient detail to show complete compliance with the intent of each section in this Specification.
- C. Experience Documentation: Manufacturer shall be regularly engaged in the manufacture of ultraviolet water purifiers for a period of at least 10 years.

1.5 QUALITY ASSURANCE

- A. System Performance Guarantee: The system must be guaranteed to perform bacteriologically in accordance with this Specification. The UV dose produced shall not be less than 60,000 $\mu\text{W}\cdot\text{s}/\text{cm}^2$ (microwatt-seconds per square centimeter) and have a kill rate of 99.99%. Manufacturer must have documentation at least three of its units operating successfully for two years in a treatment facility environment with fecal coliform effluent limits of less than 23 colonies per 100 ml for thirty (30) days.
- B. Manufacturer's Warranty: The manufacturer must guarantee the product against defects in material and workmanship for a period of one (1) year from the shipment date.

PART 2 PRODUCTS

2.1 CAST-IN-PLACE CONCRETE

- A. All cast-in-place concrete to be ready-mix meeting ASTM C 94-65 with a minimum of 6 bags per cubic yard.
- B. Portland Cement: ASTM C 150-66, Type 1.
- C. High Early Strength Cement: Type III or Type III-A when authorized by the PROJECT ENGINEER.

- D. Fine Aggregate: ASTM C 33-64, river sand.
 - E. Coarse Aggregate: ASTM C 33-64, crushed natural stone or gravel.
 - F. Water: Free from matter that could impair strength or suitability of concrete work.
 - G. Air-Entraining Agent: ASTM C 260-66T and produce an air content of 4 to 6 percent by volume.
 - H. Accessories: Comply with recommendations of "Manual of Standard Practice for Reinforced Concrete Construction" by CRSI, latest edition.
 - I. Form Ties: Richmond Snap - Ty No. SWSH, 3,000 lbs. or equal.
 - J. Expansion Joint Fillers:
 - 1. Exterior - ASTM D 1751-65, 1/2"
 - 2. Interior - ASTM D 175266, 1/4"
 - K. Curing Compounds: Water curing or approved equal.
 - L. Ready Mix Concrete: ASTM C 94-65.
 - M. Membrane: Polyethylene film, 0.066 inch thick.
 - N. Steel Bar Reinforcing: ASTM A 615, Grade 60.
 - O. Wire Mesh Reinforcing: ASTM A 185-64.
 - P. Only ready-mix concrete will be used.
 - Q. Proportion, generally, for minimum slump of three inches (3") for slabs on ground and to a maximum of five inches (5") for structural members.
 - R. The proportion of the concrete shall produce a mixture that will work readily with the placement method used, into corners and angles of forms and around reinforcement.
 - S. Concrete to have a minimum compressive strength of 4,000 psi at 28 days and a maximum slump of 3" for slabs and 5" for other members.
- 2.2 VAPOR BARRIERS
- A. Vapor barrier for concrete to be 6 mil polyethylene sheeting conforming to ASTM E 154-68.
- 2.3 BOND BREAKER
- A. Bond breaker material for concrete to be 30# and 90# asphalt saturated roofing felt.
- 2.4 CONCRETE SEALANT
- A. Uncovered concrete slabs shall be coated with one coat of W.R. Meadows, Inc., CS-309, non-yellowing curing and sealing compound and one coat of TIAH Acrylic Concrete Sealer, or equal.
 - B. Seal all exterior masonry units with surface applied water repellent sealer equal to Custom Masonry Sealer by ProSoCo.

- C. Split faced concrete blocks and block and block mortar have a water sealant incorporated into the mix such as Super Seal 454 or equal.

2.5 CONCRETE REINFORCING STEEL

- A. Concrete reinforcing steel bars to be black bars meeting ASTM A615, Grade 60.
- B. Concrete reinforcing mesh to be welded wire fabric, plain finish, meeting ASTM A185-64.

2.6 MASONRY UNITS

- A. Hollow Non-Load Bearing Concrete Block: ASTM C129
- B. Hollow Load Bearing Concrete Block: ASTM C90
- C. Joint Reinforcing: "Dur-O-Wal", trussed type
- D. Bond Beam Concrete: 3000 psi
- E. Bond Beam Reinforcing: ASTM A615
- F. Hydrated Lime: ASTM C207, Type S
- G. Wall Ties: 22 gauge, galvanized, corrugated steel, 7/8" wide x 7" long
- H. Masonry Grout: ASTM C476
- I. Face Brick: ASTM C216, Type FBS, Grade SW
- J. Common Brick: ASTM C62

2.7 MORTAR

- A. For work below grade, use mortar composed of one-part Portland cement, one part hydrated lime, and 3 parts sand by volume or one part Portland cement, one part masonry cement, and 6 parts sand by volume. Measure sand damp and loose.
- B. For work above grade, use mortar composed of one-part Portland cement, one part hydrated lime, and 6 parts sand, by volume. Measure sand while damp and loose.
- C. Mix materials mechanically for not less than 5 minutes.
- D. Portland Cement: ASTM C150, Type 1
- E. Masonry Cement: ASTM C91
- F. Water: Clean and free of foreign matter
- G. Hydrated Lime: ASTM C207, Type S
- H. Commercially Prepared Mortar: ASTM C387, Type S
- I. Sand: ASTM C144-81, natural
- J. Water Seal Admixture: Super Seal 454 or equal.

2.8 LUMBER

- A. Framing, bracing and blocking: Grade marked No. 2 Commercial Southern Yellow Pine, kiln dried to maximum moisture content of 19%.

- B. Use pressure preservative treated lumber for wood coming in contact with masonry, steel, or concrete and wood used in roof and cornice construction. Wood treatment to be Wolman salt treatment.

2.9 PLYWOOD SHEATHING

- A. Roof: ½" C-D 32/16 interior – APA plywood with exterior glue, complete with H ply clips.

2.10 CEILING INSULATION

- A. Batt Insulation: Unfaced fiberglass conforming to Federal Spec. HH-1521F, Type 1, R-30 rated.

2.11 BLOCK INSULATION

- A. Plastic foam insulation for block walls shall be two-component system consisting of an aqueous plastic three-polymer resin combined with a catalyst and compressed air to form the plastic foam equal to Poly-Master Plastic Foam.

2.12 FRAMING ACCESSORIES

- A. Nails, Spike, and Staples: Galvanized for exterior locations and treated wood; plain finish for other interior locations.
- B. Bolts, Washers, Lags, Pins, Screws: Medium carbon steel; galvanized for exterior locations or treated wood; plain finish for other interior locations.
- C. Masonry Anchors: Phillips Drill Co. Red Head self-drilling anchors or equal.
- D. Wall Strap Bracing: 2" x 6" 12-gauge galvanized sheet steel, min. 33 ksi yield strength.
- E. Framing Anchors: Simpson Co. Model No. 1 or equal.
- F. Rafter Ties: Rafter ties to be hurricane rated.

2.13 SHINGLE ROOFING AND FLASHING

- A. Shingles: Roofing shingles shall conform to Federal Spec. SS-S-294a, Class A fiberglass, self-sealing type, approximately 220 pounds/square; 20-year pro-rated warranty.
- B. Underlayment: 15 lb. unperforated asphalt saturated felt.
- C. Roofing Nails: Shingle-type of hot-dipped zinc coated steel; minimum 13/64-inch head diameter and 0.08-inch shank diameter; minimum 1¼" long.
- D. Lap Cement: Fibrated cutback asphalt type
- E. Sheet Flashing: 0.03-inch thick aluminum ASTM B209
- F. Bituminous Paint: Acid and alkali resistant; black color.

2.14 METAL ROOFING

- A. Sheet metal roofing to be 24 gauge HDG G90 galvanized steel with Kynar 500 fluoropolymer coating. Construction to be standing seam system with 1" high maximum ribs and 20" minimum panel width. Provide concealed fasteners, flashings, and other accessories recommended by the manufacturer.
- B. Underlayment for metal roofing to be red-resin paper over 30# unperforated asphalt felt.
- C. Manufacturer shall provide a 20-year structural warranty against failure under normal conditions and a 30-year finish warranty against peeling, blistering, chalking, or fading.
- D. Install in accordance with current SMACNA standards for architectural sheet metal and manufacturer's recommendations.

2.15 CAULK AND SEALANT

- A. Exterior Sealant: Single component clear silicone; Synthacalk GC 5 by Pecora, Inc. or equal.
- B. Interior Caulk: Single component clear silicone.
- C. Primer: P-53 Primer by Pecora, Inc. or equal.
- D. Back-up: Filler No. 88 by Pecora, Inc. or equal.

2.16 DOORS, HARDWARE, AND WINDOWS

- A. Exterior Door:
 - 1. Exterior steel single door shall be 42" wide, 1 $\frac{3}{4}$ " thick, constructed of 16-gauge steel with face sheets connected by 20-gauge vertical stiffeners and sound deadening material between stiffeners.
 - 2. Doors shall include weatherstripping.
 - 3. Frame shall be constructed of 16-gauge steel with all corners mitered and welded.
 - 4. Doors and frames to have a minimum of one coat of a rust inhibitive baked-on primer and two field applied exterior enamel finish coats.
 - 5. Doors to be as manufactured by Security Metal Products Corp. or equal. Double doors are not allowed.
- B. Hardware:
 - 1. Hardware for exterior steel door to be Hager Company 3500 Series Function No. 53 entry compatible with small format interchangeable core key set and #614 HD, Hold Open Door Closer as manufactured by Design Hardware or equal.
- C. Thresholds: Install aluminum thresholds on all exterior doors.

2.17 PAINT

- A. Paint shall be as manufactured by Sherwin Williams Co. or approved equal.
1. Paint Schedule: (Sherwin Williams Co.)
- a. Wood Surfaces:
- i. Interior
- (i) Primer: Problock latex, one coat
- (ii) Finish: Pro-Mar 200 latex semi-glass, two coats
- ii. Exterior
- (i) Primer: A – 100 latex, one coat
- (ii) Finish: A – 100 satin latex, two coats.
- b. Concrete Block:
- (i) Interior
- (ii) Primer: Block Filler, one coat
- (iii) Finish: Pro-Mar 200 latex, two coats
- c. Ferrous Metals:
- i. Interior
- (i) Primer: Rust-Oleum Primer, one coat
- (ii) Finish: Rust-Oleum Enamel, two coats
- (iii) Color: Smoke Gray

2.18 VINYL SIDING AND SOFFIT

- A. Rigid vinyl siding and soffit shall be manufactured principally of PVC compound Class Number 2 prepared from PVC homopolymer resin and conform to ASTM D3679. Thickness to be 0.040" minimum.
- B. Install according to manufacturer's instructions with all joint members plumb and true. Clean all soiled areas after construction.
- C. Vinyl siding and soffit material to have a lifetime limited manufacturer's warranty.

2.19 LIGHTING

- A. Provide indoor overhead fluorescent lighting.
- B. Outside lighting above the door to have photo cell with motion detector activation.

2.20 WATER SPIGOT

- A. Exterior wall water spigot shall be $\frac{3}{4}$ ", brass body, handwheel operator, frost proof sillcock, anti-siphon type. Interior spigot shall be $\frac{3}{4}$ ", brass body, anti-siphon type. Spigots shall be rated for 125 psi working pressure.

2.21 HVAC EQUIPMENT

A. Heating:

1. Heating unit shall be ceiling mounted, fan forced horizontal discharge unit, 240-volt, single phase, 3.3 KW, 11,200 BTU. Heater to be Model H1HUH03003T as manufactured by TPI Corp. or approved equal.

B. Ventilation:

1. Ventilation unit shall be 12" x 12" aluminum shutter mounted, direct drive 3-speed exhaust fan with thermostat, 120 Volt, single phase, 1/12 HP, 2750 cfm. Ventilator to be Model CE 12-DS as manufactured by TPI Corp. or approved equal.

C. Thermostat

1. Thermostats to be line voltage, wall-mounted, ET Series as manufactured by Raywall or approved equal.

2.22 ULTRAVIOLET DISINFECTION:

A. Each chamber shall be totally self-contained including lamp, quartz jacket, ballast, and wiper system.

B. Each chamber shall be designed so that lamp may be easily replaced without draining the chamber.

C. Design, Construction and Materials

1. All wetted components shall be stainless steel type 304, quartz, Teflon, or Neoprene.
2. All electronics and electrical components shall be protected in a housing, mounted directly to the disinfection chamber.
3. The exterior surfaces of the chamber shall be electropolished and passivated.
4. The chamber head shall be removable at one end of the chamber to allow access to the interior for the purpose of visual inspection and flushing any accumulated solids.
5. The maximum allowable operating pressure shall be 100 psi.
6. Each chamber shall provide a minimum contact time of 4 seconds.
7. The ultraviolet lamps are to be protected from contact with the effluent by a quartz jacket with a minimum transmission at 2537 Angstroms of 90%.

D. Lamp Array Configuration

1. Lamp shall be centered within the chamber to provide a balanced and uniform dosage throughout the chamber.

E. Ultraviolet Lamps

1. The lamps shall be low pressure, instant start, mercury arc germicidal lamps.
2. Lamps shall produce ultraviolet light with at least 90% of the ultraviolet output at 253.7 nm.
3. The arc length of each lamp shall be 37- 15/16 inches.
4. Lamps shall produce a minimum ultraviolet output of 45 watts.
5. Lamps shall be rated to produce minimum levels of ozone.
6. The number of ultraviolet lamps required shall be determined and guaranteed to be sufficient by the manufacturer.
7. Lamp ballast shall be of the high-power factor type with internal automatic reset thermally protected, 120 volt @ 60 cycles, single phase.
8. Manufacturer: The lamps shall be manufactured by Atlantic Ultraviolet Corporation or approved equal. This reference is given as an indication of the quality of material and workmanship.

F. Lamp Sleeves

1. The lamp sleeves shall be Type 214 clear fused quartz circular tubing. They shall be rated for UV transmission of 89% and not subject to solarization.
2. The quartz sleeves shall be fitted to the contact chamber with compression glands.
3. The gland nut shall be machined from brass material. It shall provide a seat for an internal and external o-ring.
4. A stainless steel type 304 push-on cap shall seal against the external o-ring on the gland nut to protect the lamps and quartz sleeve from the outside environment. The cap shall permit access to the lamps and quartz sleeves for cleaning and replacing without the use of any tools.

G. Cleaning System

1. Each chamber shall contain a wiper system to allow cleaning of quartz sleeves as often as the system requires. The system is to be completely self-contained within the chamber.
2. Each chamber shall contain a minimum of one ¼" NPT drain to allow the chamber to be 100% emptied.

H. Replacement Parts

1. The UV unit shall be capable of using lamps from at least two (2) currently active lamp manufacturers without modifications to the unit.

I. Manufacturer

1. The ultraviolet disinfection equipment shall be Sanitron as manufactured by Atlantic Ultraviolet Corporation of Hauppauge, New York.
2. Alternate manufacturer will be considered as equal, providing the microbiological performance, operation and maintenance features and warranties can be provided.

2.23 SOLENOID CONTROL VALVE

- A. Solenoid control valve for flow through the disc filters shall utilize the double-chambered actuator and a three-way brass, 24V AC, 1/8" solenoid to alternately apply upstream pressure to the upper control chamber to close and vent to drain to open.
- B. Combination Flow Meter/Hydraulic Valve
 1. Meter/valve shall consist of a turbine type water meter and a diaphragm actuated solenoid control valve in a single epoxy-coated cast iron body. It shall automatically open and close in response to a 24V DC electrical signal. Output signal shall be 4-20 mA. Meter uses a gear mechanism, which activates a reed switch to transmit a pulse at a pre-determined flow.

2.24 DISC FILTERS

- A. Disc filters shall consist of flat, grooved polypropylene rings with a center hole, stacked to form a cylindrical filter element. Rings shall be filter to 115 microns. Filter shall be rated at a minimum 140-psi working pressure and 50 psi backwash pressure. Filter housing to be constructed of reinforced polyamide and include drain valve at bottom. Disc filters to be installed such that they may be automatically backwashed by solenoid valve operation.

2.25 EXPANSION TANK

- A. The inlet piping for the UV assembly shall be equipped with a bladder expansion tank to control water hammer during dosing pump start-up. The tank body shall be of steel construction with an internal butyl rubber expansion membrane rated for a maximum of 150 psi.
- B. The tank shall have a volume of 2.1 gallons and be air pre-charged to 40 psi.

2.26 PRESSURE GAUGES AND TRANSMITTERS

- A. Pressure gauges shall be 4" diameter, oil filled, 0 – 100 psi drawn steel dial gauge with ¼" male NPT bottom inlet and brass ball valves for isolation and air bleeding.
- B. Pressure transducer to transmit pressure to the control panel using a 4-20 mA signal so that monitoring of disk filter performance can be done and backflushing of the filters can be activated. Transmitter shall have a 0 – 100 psi operating range.

2.27 CONTROL PANEL

- A. Telemetry (Flow-Fill-Time-Telemetry, FTTT) Control Panel with DACX Duplex Control Panel or approved equal. Install control panel on interior wall of Control Building. Provide lockable disconnect on exterior wall outside of building in sight of and no more than 50 feet from pumps.
- B. The panel will operate recirculation pumps using a Programmable Timer based on the liquid level in the treatment facility. A Pump On/High Level audible alarm float will override the timer should the level in the tank continue to rise. A Redundant Off/Low Level alarm float switch will protect the pumps from pumping dry. If the timer is overridden, pumps will run continuously until the level drops to the normal range setting.
- C. The panel will operate drip field dosing pumps using a Programmable Timer based on the level in the treatment facility as determined by a level transmitter. A Pump On/High Level alarm float will override the timer should the level in the tank continue to rise. A Redundant Off/Low Level alarm float switch will protect the pumps from pumping dry. Pumps will alternate operation, except during system flushing, in which pumps may operate simultaneously if required. Pump time to each drip field shall be programmable.

PART 3 EXECUTION

3.1 INSTALLATION:

- A. Install all products according to manufacturer's instructions at the locations shown on the plans.

3.2 STORAGE:

- A. Store in a clean, dry area.

3.3 CAULKING AND SEALING

- A. Seal all conduit penetrations, door frames, ventilation and exhaust housings, and water spigot.

- B. Remove dust, moisture, grease, glaze, and loose material that could interfere with adhesion of compound.
- C. Rake joints, if needed, to obtain a depth of ¼-inch for caulking.
- D. Pack joints more than ¾" deep, and joints not properly backed, with back-up to ¾" of finished surface.
- E. Complete caulking before finish painting is started.
- F. Protect adjacent surfaces to prevent adhering of compound.

3.4 PAINTING

- A. Clean grease, rust, mill scale or other matter from surface prior to painting.
- B. Do not apply paint when temperature is below 50°F or when moisture or excessive humidity is present.

3.5 CONCRETE

A. TESTING

1. A proposed concrete design mix by a laboratory, with 7 day and 28-day breaks, will be submitted to the PROJECT ENGINEER and EDGE for approval prior to pouring any concrete. Fine aggregate and coarse aggregate shall be tested by a laboratory and reports submitted to the PROJECT ENGINEER and EDGE for approval.
2. Field test cylinders to be furnished, made, cured, and transported to laboratory by the CONTRACTOR.
3. Make minimum three (3) cylinders for each 50 cu. yds. or major pour. Sample according to ASTM C 172-54. Perform slump test according to ASTM C 94-65.
4. Make and cure test cylinders to ASTM C 31-65.
5. Break 1 cylinder at 7 days and one cylinder at 28 days. If both cylinders meet required strength, break remaining cylinders at 28 days. If second cylinder fails to meet 28-day strength hold third cylinder for 60-day break. If first cylinder is low, extend curing period as directed by PROJECT ENGINEER and EDGE.
6. Laboratory submits to EDGE, in duplicate, all concrete test reports.

B. FORMS

1. Construct wood forms of clean, straight lumber and plywood. Seal to prevent leakage of water and fine materials.
2. Provide inspection holes as required for cleaning purposes.
3. Coat forms with non-staining oil or wet forms prior to pouring concrete.

4. Do not remove forms until concrete has attained sufficient strength to support its own weight and superimposed loads.
5. Use adjustable form ties. Metal not permitted closer than $\frac{3}{4}$ -inch to finished surface. Break excess metal off, fill hole with sand-cement grout or approved equal.

C. PLACING

1. Clean and prepare surfaces to receive concrete. Do not start placing until inspected by EDGE.
2. Install, secure and anchor reinforcing sleeve accessories and inserts before pour is started.
3. Convey concrete to point of use by crane and bucket. Use tremies where drop exceeds six feet (6'). Chutes will not be permitted.
4. Before depositing new concrete on or against hardened concrete, the existing surface shall be cleaned and saturated with water.
5. Place concrete with mechanical vibrators.
6. Concrete slabs placed on gravel fill to be placed on polyethylene. Do not use membrane if slab is poured on solid rock. Lap minimum of 4-inches.

D. CURING AND PROTECTION

1. Keep concrete wet for seven (7) days by water or water saturated covering.
2. In cold weather concrete shall be placed when temperature is at 40 degrees F. or above and rising. Suitable means shall be provided for maintaining concrete at a temperature of 50 degrees F., or more for a period of 72 hours after placing.

E. FINISH

1. All permanently exposed wall surfaces will be rubbed carborundum stone or as noted on drawings, within 7 days from removal of forms.
2. Remove small projections and fins.
3. Interior floor surfaces to be float surface and when sufficiently hardened, trowel to a smooth, dense and even surface. Do not sprinkle with dry cement, sand or mixture.
4. Finish exterior stairs, steps, platforms, landings, and walks light brushing with a fiber broom.
5. Should the finish not be smooth to EDGE'S approval, CONTRACTOR will be required to replace surface as directed by EDGE.

F. JOINTS

1. All construction joints below water level in water holding tanks or basins or below ground level in any structures shall include a four-inch (4") vinyl waterstop, Cat. No. R4-316T, Vinylex Corp., Knoxville, Tennessee, or equal. Splicing to be by Vinylex WS-1 splicing iron or approved equal and according to manufacturer's recommendations.
2. All joints between new and existing concrete which would require a waterstop above shall use a water-stop method and material as approved by EDGE.

G. REINFORCING

1. Comply with applicable recommendations of A.C.I. and C.R.S.I. for fabrication and placing reinforcing.
2. Place, support, and tie reinforcing to prevent displacement. Do not use welding instead of tie wire.
3. Lap mesh at ends and side at least twelve inches (12").

H. SEALING

1. All exposed concrete slabs not to be covered with tile, etc., to be coated with one (1) coat of W. R. Meadows, Inc., CS-309, Non-Yellowing Curing and Sealing Compound and one coat of TIAH Acrylic Concrete Sealer, or equals, applied in accordance with manufacturer's instructions.

3.6 EXTERIOR WOOD PROTECTION

- A. All exterior wood surfaces shall be covered with coated aluminum coil stock.

3.7 ULTRAVIOLET DISINFECTION EQUIPMENT

A. Equipment Installation

1. The manufacturer shall provide all necessary documentation to conduct a proper installation.
2. A manufacturer's representative shall inspect the installation.
3. The manufacturer's representative shall be experienced in the operation and maintenance of the specified equipment.
4. The manufacturer's representative shall certify that the installation is correct and that the equipment has operated satisfactory.

B. Performance Test

1. Testing of the ultraviolet disinfection equipment shall be performed as a field test once the installation and operation of the equipment has been certified correct.

2. Testing shall be done in accordance with the maintenance manual.

3.8 DISC FILTERS

- A. Disc filters to be installed such that they may be automatically backwashed by solenoid valve operation.

END OF SECTION 13 15 16

PART 1 GENERAL

1.1 RELATED DOCUMENTS

- A. Drawings and general provisions of the Contract, including General and Supplementary Conditions and Division 01 Specification Sections, apply to this Section.
- B. The design of the effluent collection system shall comply with Section 01 33 16 DESIGN REQUIREMENTS.
- C. EDGE's detail drawings numbers 01 through 14 apply to this section.
- D. Specification sections:
 - 1. 01 33 16 DESIGN REQUIREMENTS
 - 2. 22 13 43 EFFLUENT PUMPS
 - 3. 22 13 53 EFFLUENT TANKS
 - 4. 32 84 13 EFFLUENT DRIP DISPERSAL

1.2 SUMMARY

- A. Section Includes:
 - 1. Ductile-iron fittings.
 - 2. PVC pipe and fittings.
 - 3. Non-pressure-type transition couplings.
 - 4. Pressure-type pipe couplings.
 - 5. Valves.
 - 6. Encasement for piping.
 - 7. Tracer wire.
 - 8. Concrete.

1.3 ACTION SUBMITTALS

- A. Product Data: For the following:
 - 1. Pipe and fittings.
 - 2. Non-pressure and pressure couplings.
 - 3. Valves.
 - 4. Tracer wire.

1.4 INFORMATIONAL SUBMITTALS

- A. Coordination Drawings:
 - 1. Show pipe sizes, locations, and elevations. Show other piping in same trench and clearances from effluent system piping. Indicate interface and spatial relationship between piping and proximate structures. Comply with EDGE WASTEWATER's Detail Drawings relative to the collection system's spatial relationships.

2. Show system piping in profile. Draw profiles to horizontal scale of not less than 1-inch equals 50 feet and to vertical scale of not less than 1-inch equals 5 feet. Indicate blowoffs and piping. Show types, sizes, materials, and elevations of other utilities crossing system piping.

- B. Product Certificates: For each type of pipe and fitting.
- C. Field quality-control reports.

1.5 DELIVERY, STORAGE, AND HANDLING

- A. Do not store plastic pipe, and fittings in direct sunlight.
- B. Protect pipe, pipe fittings, and seals from dirt and damage.

1.6 FIELD CONDITIONS

- A. Interruption of Existing Sanitary Sewerage Service: Do not interrupt service to facilities occupied by EDGE WASTEWATER (EDGE) or others unless permitted under the following conditions and then only after arranging to provide temporary service according to requirements indicated:

1. Notify EDGE no fewer than 2 days in advance of proposed interruption of service.
2. Do not proceed with interruption of service without EDGE's written permission.

PART 2 PRODUCTS

2.1 GENERAL

- A. The installer is responsible for furnishing all material, equipment, tools, and labor in connection with the effluent collection main, complete and in accordance with the drawings and these Specifications. The installer shall be responsible for safely storing materials needed for the work. Keep the interiors of all pipes, fittings, and other accessories free from dirt and foreign matter at all times.
- B. All fittings, components, and piping for gravity mains and force mains shall be in accordance with these specifications (Schedule 40 PVC pressure fittings, Schedule 40 or Class 200 piping, etc.).

2.2 COLLECTION PIPES

- A. All plastic pipe shall be made from Class 12454-B polyvinyl chloride plastic as defined by ASTM D1784.
- B. All Class 200 pipes (200 pressure rating) shall have NSF approval and be manufactured in accordance with ASTM D2241.
- C. Pipe Certifications:

EFFLUENT COLLECTION SYSTEM

1. Furnish a certificate from the pipe manufacturer stating that the company is fully competent to manufacture PVC pipe of uniform texture and strength and in full compliance with these specifications and further stating that he has manufactured such pipe and done so in sufficient quantities to be certain that it will meet all normal field conditions.
 2. Certain information shall be applied to each piece of pipe. At the least, this shall consist of:
 - a. Nominal Size
 - b. Type of Material
 - c. SDR or Class
 - d. Manufacturer
 - e. NSF Seal of Approval
 3. Pipe that fails to comply with the requirements set forth in these specifications shall be rejected.
- D. Pipe Sizes:
1. Pipe 1 ¼ through 2 ½ inches may be solvent weld Sch. 40 PVC.
 2. Pipe 3-inches in diameter and larger shall have mechanical joints. Mechanical joints shall consist of ductile iron mechanical joint bells conforming to AWWA C111, complete with rubber gaskets, gland rings, and high-strength bolts and nuts. All joint components shall be rated equal to or greater than the pipe pressure rating.
 3. Fittings shall be ductile iron conforming to AWWA C153 or AWWA C110, with pressure rating equal to or greater than the pipe.
 4. PVC Collection pipe 4-inches or smaller must be SDR 17 unless approved by EDGE (Sch. 40).
 5. PVC Collection pipe 6-inches and above may be SDR 21.
 6. Other materials (PE) will be determined on a site-by-site basis.
- E. The spigot end of each pipe shall be beveled so that it can be easily inserted into the gasket joint, which in turn shall be designed so that the spigot end may move in the socket as the pipe expands or contracts.

- F. Pipe Gaskets shall be made of vulcanized natural or synthetic rubber; no reclaimed rubber will be allowed. The gaskets shall be of the manufacturer's standard design dimensions and of such size and shape as to provide a positive seal under all combinations of joint and gasket tolerance. The gasket and annular groove shall be designed and shaped so that when the joint is assembled, the gasket will be radially compressed to the pipe and locked in place against displacement, thus forming a positive seal.
- G. Fittings/Joints
1. Force mains:
 - a. No gravity, DWV (non-pressure), or thin-walled fittings or pipe will be accepted.
 - b. Fittings for use on PVC pressure pipe of less than 4-inch nominal inside diameter shall be Schedule 40 PVC pressure fittings unless shown otherwise on the drawings.
 - c. Fittings for use on PVC pressure pipe of 4-inch nominal inside diameter or greater shall be ductile iron with restrained mechanical joints as described in ANSI 21.10/AWWA C110 or ANSI 21.53/AWWA C153. Coatings and linings of fittings shall be as specified for ductile iron pipe. Mechanical joints for fittings shall be supplied with rubber gasket joints in conformance with ANSI 21.11/AWWA C111.
 2. Gravity mains:
 - a. Fittings 4-inches or greater shall be of mechanical joint design as defined by ANSI 8/AWWA C110/A21.10.
 - b. All fittings for gravity mains shall be in accordance with these specifications for the 1. Force mains as listed above (Schedule 40 PVC pressure fittings).

2.3 VALVES

- A. General:
1. Valves shall open counterclockwise (left) unless otherwise specified. Each valve body or operator shall have cast thereon word OPEN and an arrow indicating direction to open.
 2. All valves to be buried, submerged, or otherwise below grade valves shall be designed for such installation.
- B. Sizes

EFFLUENT COLLECTION SYSTEM

1. Valves smaller than 2-inches in nominal diameter shall be schedule 80 PVC, easy-turn ball valves. Valves shall be King Brothers LT Series or Utility approved equal.
2. Valves over 2-inches in nominal diameter shall be iron bodied, fully brass or bronze mounted unless thermoplastic valves are specifically called for in specifications or drawings or are required for given service.
3. All buried, submerged, or otherwise below grade valves, and interior valves where indicated, shall be provided with a 2-inch square operating nut, valve box, extended operator, and valve position indicator as specified in this Section. Handwheel operators shall be allowed only for valves located inside structures, except where interior valves are called to also utilize an operating nut in lieu of another type of operator. Extended operators shall be provided by valve manufacturer and shall conform to valve manufacturer's recommendations for given service.
4. All buried, submerged, or otherwise below grade valve shall be provided with restrained mechanical joints conforming to AWWA C111 unless shown otherwise on Drawings and shall be designed for underground installation. Pressure class of joint shall be at a minimum same as piping system on which joint is being installed.
5. Flanged valves shall not be allowed for buried, underground, or otherwise below grade valves unless valves are installed in a vault or otherwise accessible location and then only with approval of EDGE or unless shown on Drawings. Flanges shall be 125/150-pound standard conforming to ANSI B16.1.

C. Gate Valves

1. Gate valves shall conform to AWWA Standard C500 and shall be of iron body, bronze mounted, double-disc type with outside screws and yokes. Valves shall be constructed with bolted bonnets, provided with cast iron stuffing boxes having bolted followers. Stuffing boxes shall be so arranged as to be readily accessible and shall be packed ready for use with synthetic fiber, graphite impregnated stuffing.
2. Underground gate valves shall be American Flow Control, Mueller, US Pipe Co., M&H Valve Company, Kennedy, or approved equal.

D. Air Release Valves:

EFFLUENT COLLECTION SYSTEM

1. For sewage force and gravity mains shall be similar and equal to Bermad and the valves and assemblies of similar quality. All piping for air release valves shall be Schedule 40 PVC.
 2. For 6-inch and larger mains, a 2-inch air release valve must be used.
 3. For 4-inch and under mains, a 1-inch air release may be installed.
- E. Check Valves:
1. Main line swing-type check valves used on PVC collection and main lines 3-inches in diameter shall be Flo Control 1520-30. Main Line Swing-type check valves used on PVC collection and main lines 4-inches in diameter shall be Flo Control 1520-40.
 2. Flap check valves used on PVC lines from the interceptor tank outlet to the service connection tap shall be PVC as manufactured by King Brothers (model #KSCC-2000-S for 2-inch lines, model #KSCC-1250-S for 1 ¼-inch lines) or NDS (model #1520C20 for 2-inch lines, model #1520C12 for 1 ¼-inch lines). For collection systems designed with working pressures greater than 125 psi, consult with EDGE.
- F. Water Line Lockout Valve
1. To be installed in the customer's water line on the customer's side of the water meter. Valve shall be Mueller 300 Ball Straight Service – F.I.P. x F.I.P. Quarter turn lock wing of the same size diameter as the water line. (installation requires a 12" long brass pipe nipple of the same size diameter as the water line)
- G. Sewer Cleanout Relief Valve
1. Shall be Sewer Popper – Part #S62-304 as supplied by Jones Stephens Corp.
- H. Valve Boxes
1. Service Connection:
 - a. Valve boxes in non-traffic areas shall be NDS D1800-DISG.
 - b. Valve Boxes in traffic areas shall be of a solid one-piece cast iron and cast-iron traffic lid.
 - c. The cover shall be green, of the Standard Drop-in variety, and must be marked "SEWER."

EFFLUENT COLLECTION SYSTEM

2. Collection System/Force Main Lines - Valve boxes shall be made of good quality cast iron and shall be of sectional adjustable type. Long section shall be 5-1/4 inches in inside diameter and fit around stuffing box of valve; or over valve operator, if a two-section box is used; or to fit a circular or oval-base section if a three-section box is used. Valve boxes shall be properly sized to accept a valve position indicator as described below. Valve boxes shall be heavy roadway type.
 - a. Upper section shall be arranged to screw on over adjoining long section and shall also be full diameter. Screw-type valve boxes shall be used unless otherwise specified. Valve boxes shall be provided with cast iron lids or covers.
 - b. Lids or covers shall be marked and painted for service for which valve is used by casting words such as "SEWER", "RECLAIMED WATER", etc. Lids marked for sewer shall be painted green, lids marked for reuse shall be painted purple. An arrow shall be provided on cover to indicate direction in which valve is turned to open; this arrow shall be labeled with word "OPEN".
 - c. Overall length of each valve box shall be sufficient to permit top of box to be set flush with established finished grade. In asphalt concrete pavements, top of box to be set 1/2-inch below finished grade. Asphalt concrete to be compacted 12 inches wide around upper section for a depth of 12 inches below finished grade.
 - d. Valve boxes shall be set truly vertical and fully supported until sufficient backfill has been placed and compacted to ensure vertical alignment of box.
3. Water Line Lockout Valve
 - a. In non-traffic areas shall be NDS D1100 or approved equal.
 - b. In traffic areas shall be of a solid one-piece cast iron and cast-iron traffic lid.

2.4 ENCASEMENT FOR PIPING

- A. Standard: ASTM A 674 or AWWA C105/A21.5.

- B. For typical road crossings, use Schedule 40 PVC Pipe, two sizes larger than pipe being sleeved. Top of casing pipe shall be 30-inches below roadbed.
- C. For typical state road crossings, use welded steel casing (installed by jack and bore), two sizes larger than pipe being sleeved, per OWNER's detail Drawing Number 10. Top of casing pipe shall be a minimum of 36-inches below roadbed, complying with all the Department of Transportation requirements.

2.5 TRACER WIRE

- A. Tracer wire (detector wire, toning wire) shall be #14 (minimum) AWG, PVC coated solid copper wire (green color).
- B. Tracer wire shall be taped to all pipes continuously, using waterproof silicone wire nuts where wires tie together.
- C. Loop tracer wire up to grade level at all risers, valve and meter boxes.

2.6 CONCRETE

- A. General: Cast-in-place concrete complying with ACI 318, ACI 350, and the following:
 - 1. Cement: ASTM C 150, Type II.
 - 2. Fine Aggregate: ASTM C 33, sand.
 - 3. Coarse Aggregate: ASTM C 33, crushed gravel.
 - 4. Water: Potable.
- B. Portland Cement Design Mix: 4000 psi minimum, with 0.45 maximum water/cementitious materials ratio.
 - 1. Reinforcing Fabric: ASTM A 1064, steel, welded wire fabric, plain.
 - 2. Reinforcing Bars: ASTM A 615, Grade 60 deformed steel.
- C. Ballast and Pipe Supports: Portland cement design mix, 3000 psi minimum, with 0.58 maximum water/cementitious materials ratio.
 - 1. Reinforcing Fabric: ASTM A1064, steel, welded wire fabric, plain.
 - 2. Reinforcing Bars: ASTM A 615, Grade 60 deformed steel.

PART 3 EXECUTION

3.1 EARTHWORK

- A. Excavating, trenching, and backfilling are specified in Section 312000 "EARTH MOVING."

3.2 PIPING INSTALLATION

EFFLUENT COLLECTION SYSTEM

- A. General Locations and Arrangements: Drawing plans and details to indicate general location and arrangement of underground effluent sewer piping. Location and arrangement of piping layout take into account design considerations. Install piping as indicated, to extent practical. Where specific installation is not indicated, follow piping manufacturer's written instructions.
- B. Install proper size increasers, reducers, and couplings where different sizes or materials of pipes and fittings are connected. Reducing size of piping in direction of flow is prohibited.
- C. Gravity Mains: Install gravity-flow, non-pressure, drainage piping according to the following:
 - 1. Lay the gravity main to keep it at the lines and grades required by the approved drawings stamped by EDGE.
 - 2. Gravity mains shall be a minimum of 4-inches in diameter. Four-inch diameter mains shall have no less than 1% fall (1' drop in elevation for every 100 linear feet of pipe) towards the pump station. If the main falls to less than 1% for more than 100 ft., a six-inch pipe must be installed. Gravity mains that are 6" may be laid at 0.5% fall (6" drop in elevation for every 100 feet).
 - 3. If gravity main has any swags (ups and downs), then an air release assembly as per specs in Part 1 above shall be installed at every high point in the main, for all diameters of pipes. Main shall have a minimum depth as per approved plans, and shall have a tracer wire taped to it. If there are any rocks in gravity main ditch, the pipe shall be bedded in 6" of crusher-run, #67 gravel, or similar fill material. Then, pipes are to be covered in a minimum of one (1) foot of soil or EDGE approved granular material before rest of backfill is placed.
 - 4. Install PVC gravity sewer piping according to ASTM D 2321.
 - 5. Gravity main shall be installed with a minimum of 30" cover over the pipe.
 - 6. If there are any rocks in force main ditch, the pipe shall be bedded in 6-inches of crusher-run, #67 gravel, or similar fill material. Then, pipes are to be covered in a minimum of one (1) foot of soil or EDGE approved granular material before remainder of backfill is placed.
 - 7. All work must be inspected by EDGE prior to backfilling. Install PVC gravity main as per Utility approved plans.
- D. Force Mains: Install force main, pressure piping according to the following:

EFFLUENT COLLECTION SYSTEM

1. Install ductile-iron special fittings according to AWWA C600.
 2. Install PVC pressure piping according to AWWA M23 or to ASTM D 2774 and ASTM F 1668.
 3. Force mains shall be installed with a minimum of 30-inches of cover over the pipe. If there are any rocks in force main ditch, the pipe shall be bedded in 6" of crusher-run, #67 gravel, or similar fill material. Then, pipes are to be covered in a minimum of one-foot of soil or EDGE approved granular material before remainder of backfill is placed.
- E. Encasement: When installing service line or force main pipe under streets, encase in Schedule 40 PVC pipe sleeve the full distance of the street crossing. Encasement pipe shall be 2 sizes larger than pipe being sleeved.
- F. Service connections (sewer taps) for each residence shall consist of a 2" ball valve, a clear 2" check valve, and a meter box covering these components. The components shall be as specified in Part 1 of this document. The check valve shall be installed between the septic tank and the ball valve, with the check valve pointing away from the tank. Top of meter box marked "Sewer" shall be installed with top of box even with final grade. Construct as shown on EDGE's drawing titled TYPICAL SERVICE CONNECTION (PRESSURE).
- G. All pipes installed in ground shall have a tracer wire taped to them.
- H. All work must be inspected by EDGE prior to backfilling.

3.3 PIPE JOINT CONSTRUCTION

- A. Join gravity-flow, non-pressure, drainage piping according to the following:
1. Join PVC corrugated sewer piping according to ASTM D 2321.
 2. Join PVC gravity sewer piping according to ASTM D 2321 and ASTM D 3034 for elastomeric-seal joints or ASTM D 3034 for elastomeric-gasket joints.
 3. Join dissimilar pipe materials with non-pressure-type, flexible couplings.
- B. Join force-main, pressure piping according to the following:
1. Join PVC pressure piping according to AWWA M23 for gasketed joints.
 2. Join dissimilar pipe materials with pressure-type couplings.

- C. Pipe couplings, expansion joints, and deflection fittings with pressure ratings at least equal to piping rating may be used in applications below unless otherwise indicated.
 - 1. Use non-pressure flexible couplings where required to join gravity-flow, non-pressure sewer piping unless otherwise indicated.
 - a. Shielded flexible or rigid couplings for pipes of same or slightly different OD.
 - b. Unshielded, increaser/reducer-pattern, flexible or rigid couplings for pipes with different OD.
 - c. Ring-type flexible couplings for piping of different sizes where annular space between smaller piping's OD and larger piping's ID permits installation.
 - 2. Use pressure pipe couplings for force-main joints.

3.4 CONCRETE PLACEMENT

- A. Place cast-in-place concrete according to ACI 318.

3.5 SERVICE LINES: Installation of gravity and pressure service lines and service connections (taps) shall be met as follows:

- A. Install an EDGE approved watertight tank and test it according to these specifications.
- B. Measure the appropriate grade level for the riser. If necessary, cut the bottom of the riser to the correct height (drilled and tapped holes are on the top.)
- C. Clean the area around the opening of the tank and the bottom mounting surface of the riser (inside surface up to 1 ½-inch) with PVC cleaner using a rag or applicator.
- D. If using a concrete tank with a grooved mounting surface:
 - 1. Mix ADHQ10 two-part epoxy and coat epoxy on grooved mounting surface allowing epoxy to run down into the groove.
 - 2. Place the riser in the grooved mounting surface of the tank.
 - 3. After mounting the riser pour epoxy between the inside of the riser and the grooved tank mounting surface.
 - 4. Twist the riser for a tight fit.
 - 5. Fill in gaps with the epoxy.
 - 6. Epoxy will set in (4) hours and reach full strength in 24 hours at 70 degrees F and above.
- E. If using a concrete tank with a black riser mounting ring:
 - 1. Apply Sikaflex 11FC around the outside of the black riser mounting ring approximately 1" from the top.

EFFLUENT COLLECTION SYSTEM

2. Apply Sikaflex 11FC around the inside of the riser approximately 1 ½"-2" from the bottom of the riser.
 3. Place the riser on the black riser mounting ring.
 4. Twist the riser for a tight fit.
 5. Fill in the gaps by running a bead of Sikaflex 11FC along the inside of the riser where the black riser mounting ring and riser meet.
- F. If using a fiberglass tank:
1. Apply ADHQ10 around the outside of the fiberglass tank approximately 1" from the top.
 2. Apply ADHQ10 around the inside of the riser approximately 1 ½"-2" from the bottom of the riser.
 3. Place the riser on the tank.
 4. Twist the riser for a tight fit.
 5. Fill in gaps by running a bead of ADHQ10 along the inside of the tank where the tank and riser meet.
 6. Epoxy will set in (4) hours and reach full strength in 24 hours at 70 degrees F and above.
- G. Install the pump vault by sliding it down in the tank opening inside the mounting ring (the hanger brackets should sit on top of the concrete surface depending on the concentricity of the tank opening.)
- H. Trim the hanger brackets if necessary.
- I. Move the pump chamber so that it is located 180 degrees from the intended exit location of the discharge line.
- J. Select the location where the conduit exits the pump vault (generally in a straight line to the control panel location on the building.)
- K. Mark the location of the (3) conduit holes approximately 2-inches above the mounting surface and generally 2-inches center to center.
- L. Remove the outside riser fins with a flat blade bit or other tool (ensure that the riser fin surface is cut until it is even with the adjacent surface.)
- M. Drill (3) holes 1-inch in diameter on 2-inch centers for the ½-inch grommet installation (trim any edge material so that the holes are smooth and even.)
- N. Select the location of the discharge line (usually in a straight line in the direction of the tap at the collection line) and remove the outside riser fins with a flat blade bit or suitable tool.

- O. Drill one hole 1 9/16-inches in diameter for the installation of the 1-inch grommet (trim any edge material so that the holes are smooth and even.)
- P. Install the control panel SF1-ETM-ADT on the side of the building near the tank (the control panel should be installed according to the electrical code.)
- Q. The three #10 wires (power, neutral, ground) from the building should run from a 30-amp single pole breaker and come out the side of the building through the control panel.
- R. Install (3) ½-inch grommets in the (3) 1-inch diameter holes drilled in the side of the riser.
- S. File a bevel at the end of the conduit.
- T. Lubricate the conduits and grommets with soap.
- U. Install (3) ½-inch PVC electrical conduits (schedule 40) into the (3) ½-inch rubber grommets (the conduit should extend about ¾-inch to 1-inch into the riser).
- V. Install the female adapters to (3) conduit ends.
- W. Screw the (1) gas seal for the pump cord into (1) female adapter and screw the (2) remaining gas seals for the (2) floats into the remaining female adapters.
- X. Remove the float stem assembly from inside the pump vault.
- Y. Secure top float collar 6 ½-inches down from the base of the handle on the float stem with a setscrew.
- Z. Secure bottom float collar 4 ½-inches below the top float collar.
- AA. Secure the yellow pump operating float with a 3-inch tether to the bottom float collar.
- BB. Secure the yellow alarm float with a 3-inch tether to the bottom float collar.
- CC. Use wire tie straps to keep (2) float cords and (1) pump cord organized along the float stem.
- DD. Using the small fish tape, pull the (1) pump cord and (2) float cord through the conduits into the control panel (leave approximately 5 feet of spare cord inside the vault.)
- EE. Make sure that all floats are rotated 15 to 20 degrees so that they are not in a vertical line or making contact with the vault walls.
- FF. Install the hose and valve stem into the top of the pump using thread seal. Do not use wrenches!
- GG. Attach the hose and valve discharge assembly to the hose and valve stem coming up from the pump.
- HH. Lubricate the 1-inch grommet and the gray 1-inch x 4-inch nipple on the discharge assembly with soap.

- II. Slide the 1-inch x 4-inch nipple through the 1-inch grommet in the side of the riser (the nipple should extend to the outside of the riser approximately 2-inches.)
- JJ. Adjust the discharge hose assembly that is running across the top of the vault so that it can be properly operated and is maintenance friendly.
- KK. Connect the external flex extension to the 1¼-inches service line using PVC glue.
- LL. Install 1 ¼-inches schedule 40 PVC service line pipe to the service connection.
- MM. Connect the power, neutral, and ground wires from the building to the appropriate connection points in the control panel according to the wiring diagram.
- NN. Connect the (2) float wires and (1) pump cord wire to the terminal block in the control panel according to the wiring diagram.
- OO. When connecting the main collection line, ensure that the ball shut-off valve has been installed on the service line leaving the collection line and is in working order.
- PP. Also ensure that a flapper check valve is installed on the service line from the main collection line (verify the direction of the flow arrow on the check valve is pointing towards the main collection line).
- QQ. Also ensure that the flapper is in working order and seating properly when closed.
- RR. Connect the 1 ¼-inch service line to the check valve; make sure that the glue applicator touches only the surface that will come in contact with the pipe (do not get any glue on the flapper).
- SS. Turn both circuit breakers in the control panel to the “on” position and test for 125 volts of power.
- TT. Flip the auto-off-manual toggle switch to manual and test the pump run conditions.
- UU. If pump is running flip the toggle switch to the auto position and raise the float stem to a vertical position.
- VV. Raise the pump operating float (bottom float) and check for pump running conditions.
- WW. While keeping the pump operating float (bottom float) in the raised position, raise the audio alarm float (top float), audio alarm should sound and red pushbutton should illuminate.
- XX. Lower the alarm float (top yellow float.)
- YY. Lower the pump operating float (bottom yellow float.)
- ZZ. When the pump operating float (bottom yellow float) is lowered the pump should stop.
- AAA. Install the float stem in the pump vault.

- BBB. Using the wire tie straps bundle each wire together to ensure that no loose wires fall into the pump vault, this makes it easier to raise the float stem for testing and maintenance.
- CCC. Open the ball valve at the collection line and run the pump. Verify that water is flowing properly through the check valve and ball valve by observing the clear check valve.
- DDD. With the pump running, turn the ball valve at the collection line to the off position and check for any leaks in the 1 ¼-inch service line.
- EEE. Fix leaks if necessary.
- FFF. Open the ball valve at the collection line.
- GGG. Secure lid on riser with provided stainless steel bolts.
- HHH. Note: The tank will need to be inspected to ensure that it is watertight. Contact company/person responsible for operation and maintenance before and after installation for any specifications and instructions.

3.6 CLOSING ABANDONED EFFLUENT SEWER SYSTEMS

- A. Abandoned Piping: Close open ends of abandoned underground piping indicated to remain in place. Include closures strong enough to withstand hydrostatic and earth pressures that may result after ends of abandoned piping have been closed. Use either procedure below:
 - 1. Close open ends of piping with threaded metal caps, plastic plugs, or other acceptable methods suitable for size and type of material being closed. Do not use wood plugs.
- B. Backfill to grade according to Section 312000 "Earth Moving."

3.7 IDENTIFICATION

- A. Comply with requirements in Section 312000 "Earth Moving" for underground utility identification devices. Arrange for installation of green tracer wire directly over all piping and at outside edges of underground risers, valve or meter boxes.

3.8 FIELD QUALITY CONTROL

- A. Inspect interior of piping to determine whether line displacement or other damage has occurred. Inspect after approximately 24 inches of backfill is in place, and again at completion of Project.
 - 1. Submit separate report for each system inspection.
 - 2. Defects requiring correction include the following:
 - a. Alignment: Less than full diameter of inside of pipe is visible between structures.

EFFLUENT COLLECTION SYSTEM

- b. Deflection: Flexible piping with deflection that prevents passage of ball or cylinder of size not less than 92.5 percent of piping diameter.
 - c. Damage: Crushed, broken, cracked, or otherwise damaged piping.
 - d. Infiltration: Water leakage into piping.
 - e. Exfiltration: Water leakage from or around piping.
 - 3. Replace defective piping using new materials and repeat inspections until defects are within allowances specified.
 - 4. Reinspect and repeat procedure until results are satisfactory.
- B. Test new piping systems, and parts of existing systems that have been altered, extended, or repaired, for leaks and defects.
- 1. Upon completion of force main installation, it shall be pressure tested to 150 psi. A pressure gauge shall be inserted in line with the main so pressure can easily be read. If there is no pressure loss over 6 hours of applied pressure to the whole system at 150 psi, the force main shall pass inspection.
 - 2. Upon completion of gravity main installation, it shall be pressure tested to 150 psi. A pressure gauge shall be inserted in line with the main so pressure can easily be read. If there is no pressure loss over 6 hours of applied pressure to the whole system at 150 psi, the gravity main shall pass the pressure portion of the inspection.
 - a. Test plastic gravity sewer piping according to ASTM F 1417.
 - 3. Leaks and loss in test pressure constitute defects that must be repaired.
 - 4. All piping shall be pressure tested for a period of six (6) hours at a pressure of 150 psi. A loss of more than 5 lbs. constitutes failure. All obvious leaks shall be repaired before acceptance.
 - 5. Tests of pumps, control system, meters, etc., must be made by or in the presence of EDGE's representative, and any defects noted shall be corrected before acceptance.
 - 6. Replace leaking piping using new materials, and repeat testing until leakage is within allowances specified.

3.9 CLEANING

- A. Clear interior of piping of dirt and superfluous material as work progresses. Maintain swab or drag in piping and pull past each joint as it is completed. Place plug in end of incomplete piping at end of day and when work stops.

END OF SECTION 221313

PART 1 GENERAL

1.1 SUMMARY

- A. This Section includes effluent pumps, control panels, filters, mercury switch floats, discharge assemblies.

1.2 RELATED DOCUMENTS

- A. Specification sections:
 - 1. 01 33 16 DESIGN REQUIREMENTS
 - 2. 22 13 13 EFFLUENT COLLECTION SYSTEM
 - 3. 22 13 53 EFFLUENT TANKS
 - 4. 26 05 26 GROUNDING AND BONDING FOR ELECTRICAL SYSTEMS
 - 5. 26 20 00 ELECTRICAL WORK, GENERAL
 - 6. 32 84 13 EFFLUENT DRIP DISPERSAL

1.3 PERFORMANCE REQUIREMENTS

- A. Pressure Rating of Effluent Pumps and Discharge Piping Components: At least equal to effluent pump discharge pressure, but not less than 150 psig.
- B. Pressure Rating of Other Piping Components: At least equal to system operating pressure.
- C. Tests of pumps, control system, meters, etc., must be made by or in the presence of the EDGE's representative, and any defects noted shall be corrected before acceptance.

1.4 ACTION SUBMITTALS

- A. Product Data: Include rated capacities, operating characteristics, furnished specialties, and accessories.
- B. Shop Drawings: Show fabrication and installation details for each effluent pump. Detail equipment assemblies and indicate dimensions; shipping, installed, and operating weights; loads; required clearances; method of field assembly; components; electrical characteristics; and location and size of each field connection.
- C. Wiring Diagrams: Power, signal, and control wiring.

1.5 INFORMATIONAL SUBMITTALS

- A. Product Certificates: For each type of effluent pump, signed by product manufacturer.

1.6 CLOSEOUT SUBMITTALS

- A. Operation and Maintenance Data: For equipment to include in emergency, operation, and maintenance manuals.

1.7 QUALITY ASSURANCE

- A. Installer Qualifications: 5 years local experience and show proof of experience is required for this Project.
- B. Testing Agency Qualifications: An independent agency, with 5 years experience and capability to conduct the testing indicated, that is a nationally recognized testing laboratory (NRTL) as defined by OSHA in 29 CFR 1910.7.
- C. Comply with UL 778, "Motor-Operated Water Pumps," for effluent pumps.

1.8 PROJECT CONDITIONS

- A. Interruption of Existing Sanitary Sewer Service: Do not interrupt sanitary sewer service to facilities occupied by EDGE WASTEWATER (EDGE) or others unless permitted under the following conditions and then only after arranging to provide temporary sanitary sewer service according to requirements indicated:
 - 1. Notify EDGE no fewer than two (2) days in advance of proposed interruption of sanitary sewer service.
 - 2. Do not proceed with interruption of sanitary sewer service without EDGE's written permission.

1.9 WARRANTY

- A. Special Warranty: Manufacturer's standard form in which manufacturer agrees to repair or replace components of effluent pumps that fail in materials or workmanship within specified warranty period.
 - 1. Failures include, but are not limited to, the following:
 - a. Structural failures including pump vault.
 - b. Faulty operation of effluent pumps, controls, or accessories.
 - c. Deterioration of metals, metal finishes, and other materials beyond normal use.
- B. Warranty Period for Shells: two (2) years from date of Substantial Completion.
- C. Warranty Period for Effluent Pumps and Controls: three (3) years from date of Substantial Completion.
- D. Warranty Period for Accessories: two (2) years from date of Substantial Completion.

PART 2 PRODUCTS

2.1 EFFLUENT PUMPS

- A. Submersible, high-head effluent pumps:
 - 1. Pump shall be designed by a licensed engineer in the state which it is to be used. See Section 22 13 53 TANKS for acceptable pump tanks.
- B. All pumps unless otherwise shown on the design plans, shall be 4" diameter (3-7/8" actual) submersible, high-head effluent pumps precision engineered of high-quality stainless steel with acetal impellers, polycarbonate diffusers, polycarbonate with stainless steel insert suction caps, polypropylene intake screen, and built-in acetal check valve.
- C. Shaft and coupling and the intake shall all be of stainless steel. Motors shall be appropriate voltage and wires from Franklin Electric or Pentair (PenTek), and pump end shall be similar to that of Sta-Rite and AY McDonald.
- D. Residential applications are typically equal to the STEP10 pump from Sta-Rite (10 gpm, 115Vac, 1/2 hp).
- E. Pump data shall be submitted to accepted by the Utility prior to purchase.

2.2 DISCHARGE ASSEMBLY

- A. Discharge assemblies shall include all the necessary plumbing (pipe, fittings, check valve, etc.) to convey effluent from a pump to the outside of a riser or pump basin.
- B. Assemblies shall be corrosion resistant and adjustable for a proper fit inside risers or pump basins.
- C. Flexible high-pressure hoses shall be included to dampen vibration from the pump. All fittings on hose and valve assemblies are to be either threaded and sealed with Teflon paste or solvent welded.
- D. Components shall meet or exceed the following specs:
 - 1. Ball Valve (Schedule 80 PVC, working pressure = 150+ psi @ 73° F),
- E. Internal Flex Hose (Specially compounded elastomer, synthetic, high tensile textile cord; high-pressure red flex hose, pressure rated at 200 psi for all discharge sizes),
- F. External Flex Hose (Same hose as listed above),
- G. Pipe and All Fittings (Schedule 40 PVC).
- H. 1" discharge assemblies for 10 gpm pumps shall include a flow restrictor. Discharge assemblies shall be as manufactured by a competent manufacturer with a minimum of five (5) years experience.

2.3 MERCURY SWITCH FLOAT

- A. All residential floats shall be control-duty, mercury wide angle, normally open float switches.
- B. No mechanical float switches will be accepted.
- C. Floats shall contain a steel tube mercury switch designed to operate under min/max temperatures of 32-170° F, and have an electrical rating of 10 Amps @ 120 VAC, 3 Amps @ 240 VAC.
- D. The float power cord shall be a chlorinated polyethylene type SJOW-300 Volt and 18/2.
- E. Float ball shall be constructed of a durable polypropylene outer shell and a solid polyurethane foam interior.

2.4 CONTROL PANELS

- A. General.
 - 1. All control panels must be UL certified and tested, capable of handling the specific application at hand.
- B. Residential panels shall have the following:
 - 1. Pump Circuit Breaker (20-amps, OFF/ON switch. Single pole 120 VAC, DIN rail mounting with thermal magnetic tripping characteristics).
 - 2. Controls Circuit Breaker (10-amps, OFF/ON switch. Single pole VAC. DIN rail mounting with thermal magnetic tripping characteristics).
 - 3. Toggle Switch (Single pole, double-throw HOA switch. 20-amps, 1 HP).
 - 4. Audio Alarm (95 dB at 24", warble-tone sound).
 - 5. Audio Alarm Silence Relay (120-VAC, automatic reset).
 - 6. Visual Alarm (7/8" diameter red lens, "Push to Silence." NEMA 4X, 1-watt bulb, 120 VAC).
 - 7. Padlock Latch (Constructed of non-corrosive stainless steel).
 - 8. Elapsed Time Meter (120 VAC, 6-digit, non-resettable).
 - 9. Suitable models of approved residential panels are the SF1-ETM, the GF1 and GF2, the SC1-ETM-PRL, and the SC1-RO-ETM control panels.
- C. Pump panels shall have the following:
 - 1. Hardware/Enclosure Requirements.
 - a. Certified Compatible Monitoring System.
 - b. Programmable Logic Controller capable of MODBUS TCP communication.
 - c. UL Listed.

EFFLUENT PUMPS

- d. 10 Base T/100 Base-TX Ethernet Port to network units, host web pages, and FTP server.
 - e. Compact Flash, USB, or SD card socket for on-board logging.
 - f. Configuration is stored in non-volatile memory.
 - g. UL-Type 4X Fiberglass enclosure.
 - h. Current Sensors.
 - i. Service outlet.
 - j. Isolation Relays.
 - k. TVSS protection.
 - l. Climate Control.
 - m. Verizon approved ODI M2M modem capable of running over secure hosted Verizon Wireless VPN.
- D. Operational Specification
- 1. Minimum Duplex (2) alternating pump configuration.
 - 2. 3 level float tree or submersible level sensor.
 - 3. Minimum cycle runtime.
 - 4. High level renotify timer/alarm.
 - 5. Current sensor alarming.
 - 6. Redundant OFF low-level float with emergency pump shut off.
 - 7. Suitable models of approved pump panels are the AT-DUPLEX-LTE and the AO-DAC2T-RO control panels.
- E. Treatment Plant panels shall have the following:
- 1. Hardware/Enclosure Requirements
 - a. Certified Compatible Monitoring System.
 - b. Touch Screen HMI.
 - c. Programmable Logic Controller capable of MODBUS TCP communication.
 - d. UL Listed.
 - e. Up to 5 RS-232/422/485 Serial ports.
 - f. 10 Base T/100 Base-TX Ethernet Port To network Units, host web pages, and FTP server.
 - g. Compact Flash, USB, or SD card socket for on-board logging.
 - h. Configuration is stored in non-volatile memory.
 - i. NEMA 4X / IP66 Front Panel.
 - j. Current Sensors.
 - k. Service outlet.
 - l. Isolation Relays.
 - m. TVSS protection.
 - n. Climate Control.

- o. Verizon approved ODI M2M modem capable of running over secure hosted Verizon Wireless VPN.
- 2. Software Requirements
 - a. Certified Compatible Monitoring System.
 - b. SCADA driven Adaptive Recirculation Rate.
 - c. SCADA driven Adaptive Pump Management.
 - d. Zone-specific dynamic subsurface dispersal logic providing supply/return PSI and GPM values.
 - e. Data logging.
 - 3. SCADA Requirements
 - a. Certified Compatible Monitoring System.
 - b. Remote Web Access and Control Facility over secure hosted Verizon VPN managed by Certified Verizon Vertical Solution Provider.
 - c. Alarm polling with specified user acknowledgement feature.
 - d. Key Performance Indicator email reporting.
 - e. Chart based performance reporting.
 - f. Suitable models of approved treatment plant panels are the FFRT-2R-2D-5Drip and the FFRT-12RZ-2D-15DZ control panels.

2.5 EFFLUENT FILTERS

- A. Effluent gravity filters shall have filtration of effluent from the clear zone of the septic tank to less than 3/16" and be constructed from over 2-1/4 sf of 3/16" polypropylene filter mesh encapsulated in urethane caps, top and bottom.
- B. Filter shall also have a 4" diameter Schedule 40 outlet tee with a solid plate flow reducer and a 3/4" field extendable handle for easy removal of the filter cartridge for cleaning, and a float bracket on tee.

PART 3 EXECUTION

3.1 EXAMINATION

- A. Examine substrates and conditions, with Installer present, for compliance with requirements for installation tolerances and other conditions affecting performance.
- B. Examine roughing-in of effluent piping to verify actual locations of piping connections before effluent pump installation.
- C. Proceed with installation only after unsatisfactory conditions have been corrected.

3.2 EARTHWORK

- A. Excavation, trenching, and backfilling are specified in Section 312000 "EARTH MOVING."

3.3 INSTALLATION

- A. Install effluent pump components where indicated, according to specific equipment and piping arrangement indicated.
- B. Ensure that there are no voids under slab of pump tank.
- C. Fill voids with grout.
- D. Connect anode conductors to grounding lugs on steel housing.

3.4 CONNECTIONS

- A. Sewer piping installation requirements are specified in Section 221313 "SANITARY SEWERS." Drawings indicate general arrangement of piping.
- B. Install piping to allow service and maintenance.
- C. Ground all equipment according to Section 260526 "GROUNDING AND BONDING FOR ELECTRICAL SYSTEMS."

3.5 IDENTIFICATION

- A. Install identifying labels permanently attached to equipment.
- B. Install operating instruction signs permanently attached to equipment or on pump wall near equipment.
- C. Arrange for installing green [tracer wire or toning wire] detectable warning tape over outside edges of underground effluent pumps. Tape materials and their installation are specified in Section 312000 "EARTH MOVING."

3.6 FIELD QUALITY CONTROL

- A. Contractor is to perform field tests and inspections and prepare test reports. Give sufficient notice to EDGE to allow their presence.
- B. Perform tests and inspections and prepare test reports.
- C. Tests and Inspections:
 - 1. After installing effluent pumps and after electrical circuitry has been energized, test for compliance with requirements. Furnish water required for pump tests.
 - 2. Leak Test: After installation, charge systems and test for leaks. Repair leaks and retest until no leaks exist.
 - 3. Operational Test: After electrical circuitry has been energized, start units to confirm proper motor rotation and unit operation.
 - 4. Test and adjust controls and safeties. Replace damaged and malfunctioning controls and equipment.

- D. Remove and replace effluent pumps that do not pass tests and inspections and retest as specified above.

3.7 STARTUP SERVICE

- A. Complete installation and startup checks according to manufacturer's written instructions.
- B. Adjust pumps, accessories, and control settings, and safety and alarm devices as necessary to comply with manufacturer's and EDGE's requirements.

END OF SECTION 22 13 43

PART 1 GENERAL

1.1 RELATED DOCUMENTS

- A. Drawings and general provisions of the Contract.
- B. Related Sections:
 - 1. 01 33 16 DESIGN REQUIREMENTS
 - 2. 22 13 13 EFFLUENT COLLECTION SYSTEM
 - 3. 22 13 43 EFFLUENT PUMPS
 - 4. 31 20 00 EARTH MOVING

1.2 SUMMARY

- A. This Section includes the following:
 - 1. Septic tanks, including STEP and STEG,
 - 2. Final dosing tanks, and
 - 3. Recirculating tanks.

1.3 ACTION SUBMITTALS

- A. Product Data: For each type of product indicated.
 - 1. Include construction details, material descriptions, dimensions of individual components, and profiles.
 - 2. Include manhole openings, risers, lids, and pipe connections.
- B. Shop Drawings:
 - 1. Include manhole openings, risers, lids, pipe connections, and accessories.
 - 2. Include piping with sizes and invert elevations.
 - 3. Include underground structures.
 - 4. Include other utilities.

1.4 PROJECT CONDITIONS

- A. Interruption of Existing Septic Tank System Service: Do not interrupt service to facilities occupied by EDGE or others unless permitted under the following conditions and then only after arranging to provide temporary service according to requirements indicated:
- B. Notify EDGE no fewer than two days in advance of proposed interruption of service.
- C. Do not proceed with interruption of service without EDGE's written permission.

PART 2 PRODUCTS

2.1 TANKS

- A. This section includes STEG and STEP (septic) tanks, final dosing and recirculation (chambers) tanks, described in Part 2.2 and 2.3 below.
- B. Tank Requirements
1. Tanks shall be designed to withstand H-20 traffic loading according to ASTM C 890.
 2. The tanks shall be designed for the following normal loads; top, 300 lb/sf, Lateral loads, 62 lb/sf.
 3. Tanks shall be capable of successfully withstanding an above ground static hydraulic test and shall be individually tested.
 4. Installation: All tanks shall be installed in strict accordance with the manufacturer's recommended installation instructions.
 5. Guarantee: All tanks shall be guaranteed in writing by the tank manufacturer for a period of two years from the date of delivery.
 6. Manholes: 20-inch-minimum diameter opening with HDPE or PE access risers to grade and cover. Access for PE distribution boxes may be a removable plastic cover.
 7. Pipe Connections: With seal that prevents leakage. Include watertight plugs in outlets not required.
 8. Capacity and Characteristics:
 - a. Inlet Size: as shown on the drawings.
 - b. Number of Outlets: as shown on the drawings.
 - c. Outlet Size: as shown on the drawings.
 9. Access Openings: Tanks shall be manufactured and furnished with inlet and outlet access openings the diameter and the configuration shown on the drawings. Modifications of completed tanks will not be permitted.
- C. Concrete Tank Design Requirements
1. Standards: Watertight – ASTM C1227, Sealant – ASTM C990, and Pipe Penetrations – ASTM C923, precast 5,000 PSI (28-day) reinforced-concrete, monolithically poured single chamber tank.
 2. Comply with ASTM C 913 for precast, reinforced-concrete tank and cover.

EFFLUENT TANKS

3. Walls, bottom and top of reinforced-concrete shall be designed across the shortest dimension using one-way analysis. Stresses in each face of monolithically-constructed tanks may be determined by analyzing the tank cross-section as a continuous fixed frame.
4. The walls and bottom slab shall be poured monolithically. No seams are allowed in the wall section.
5. Manufacturer must have NPCA certification and follow all NPCA production protocols in manufacturing concrete tanks.
6. Concrete shall be ready-mix with cement conforming to ASTM- C150, Type II. It shall have a cement content not less than six (6) sacks per cubic yard and maximum aggregate size of $\frac{3}{4}$ inch. Water/cement ration shall be kept low (0.35+/-), and concrete shall achieve a minimum compressive strength of 5000 psi in 28 days.
7. Designer: Tanks must be certified by a Professional Engineer qualified to do structural design in the State of Tennessee. Tanks must be structurally sound by engineer design with a minimum safety factor of 1.4.
8. Reinforcing steel shall be ASTM A-615, Grade 60, fy = 60,000 psi. Details and placement shall be in accordance with ACI 315 and ACI 318. The structural steel must be continuous from the side walls into and across the top slab.
9. Concrete Tank Curing: Tanks shall not be moved from the manufacturing site until the tank has cured for seven (7) days or has reached two-thirds of the design strength.
10. Tanks shall be concrete unless otherwise approved by the Utility engineer.

D. Plastic Tanks

1. Description: Molded-HDPE or -PE, single- or double-chamber box and cover.
2. Manholes: Refer to the drawings for minimum diameter opening with HDPE or PE access risers to grade and cover.
3. Manholes: Manufacturer's standard cover or other access opening of size that permits access to distribution-box inlet and outlets.
4. Pipe Connections: With seal that prevents leakage. Include watertight plugs in outlets not required.
5. Capacity and Characteristics:
 - a. Inlet Size: See drawings.
 - b. Number of Outlets: See drawings.
 - c. Outlet Size: See drawings.

EFFLUENT TANKS

6. List of approved plastic tanks:
 - a. Infiltrator IM-1530 including CAT 4 Fit
 - b. Snyder NexGen D2 – ASM TK 1500
- E. Fiberglass-reinforced plastic (FRP) tanks
 1. Comply with the ANSI/AWWA D120 standard.
 2. Fiberglass tanks will only be allowed on a case-by-case basis. The Utility shall approve the use only under the condition that installing a concrete tank is not practical due to location or terrain.
 3. Method of calculation
 4. Fiberglass tanks shall be analyzed using finite element analysis for buried structures.
 5. Calculations shall address the following:
 - a. Strength with a minimum safety factor of 2.5
 - b. Buckling with a minimum safety factor of 2.5
 - c. Deflection of 5% of the tank diameter, based on service load (including long term lag)
 - d. Buoyancy: Provide adequate protection against buoyancy when tanks are empty.
 6. Performance testing.
 - a. In lieu of calculations for fiberglass tanks, the supplier may elect for in-situ performance testing.
 - b. In-situ testing of each tank model shall include use of strain gauge and deflection gauge. The tank will be subjected to external forces equal to the actual load.
 - c. Maximum initial deflection based on test loading shall not exceed 2% of the tank diameter.
 - d. Performance testing will be evaluated by a Registered Professional Engineer (P.E.) approved by EDGE. The Engineer will have the sole responsibility to determine the maximum external loading on any of the tank models.
 - e. The tank shall be constructed with a glass fiber and resin content specified by the manufacturer and with no exposed glass fibers. The manufacturer shall supply to the engineer, without charge, satisfactory evidence of testing by an approved laboratory showing compliance with IAPMO IGC 3-74, excepting as herein modified. Any metal part shall be 300 series stainless steel.

EFFLUENT TANKS

- f. Inspections must be made in the supplier's facility and again after installation. The minimum wall thickness shall be $\frac{1}{4}$ inch. If the wall thickness is suspected to be less than $\frac{1}{4}$ inch or if delamination is suspected within any portion of the tank, the engineer may drill a $\frac{1}{4}$ inch diameter hole through the tank for inspection purposes. If the required minimum $\frac{1}{4}$ inch thickness is not found, repair if feasible shall be the responsibility of the contractor. If repair is judged not feasible, the tank shall be rejected. If the required minimum $\frac{1}{4}$ inch thickness is found and no delamination is present, the repair of the inspection holes shall be the responsibility of the Engineer.
- g. The Engineer shall specify the minimum weight of each tank model that will be allowed. The manufacturer will permanently mark the weight of each tank on the top near the access hole.
- h. The minimum tank weight shall be specified below by the manufacturer's engineer (i.e., 350 lbs for 1000 gallon tanks, 400 lbs for 1500 gallon tanks +/-).
- i. Holes specified for the tank shall be provided by the manufacturer. Resin shall be properly applied to all cut or ground edges so that no glass fibers are exposed and all voids are filled.
- j. Dual Tite or Ty-Seal neoprene gaskets, or approved equal, shall be used at the inlet to join the tank wall and the inlet piping. Schedule 40 PVC pipe and fittings shall be used at the inlets.
- k. Inlet plumbing shall include an inlet tee which penetrates 18 inches into the liquid from the inlet flow line. The inlet plumbing shall allow for natural ventilation back through the building sewer and vent stack.
- l. Water testing shall be performed on each tank. Every tank shall be assembled by the manufacturer and filled with water to the brim of the access opening for a minimum of two (2) hours. The tank shall show no leakage from section seams, pin-holes or other imperfections. Any leakage is cause for rejection.

EFFLUENT TANKS

- m. When leakage occurs, an additional water test shall be made on the tank after repairs have been completed. The manufacturer shall be responsible for making all corrective measures in production or assembly necessary to ensure a completely watertight tank.
 - n. After installation of the tank with riser completed, each tank shall be filled with water to a point two (2) inches into the access riser and the water loss measured after a two-hour period. Every tank test shall be witnessed by EDGEs representative. Any leakage shall be cause for rejection. Backfill of a depth equal to the water height in the riser must be in place over the tank to prevent damage due to hydrostatic uplift.
 - o. Each tank shall be marked in the upper most surface over the outlet and include weight of tank, type of tank and date of manufacture.
7. Installation shall be in accordance with manufacturer's recommendations.
8. Tank Appurtenances:
- a. Risers:
 - i. Inlet and outlet risers shall be ribbed PVC. Risers shall be at least 12- inches high, shall have a minimum nominal diameter of 24 inches when used with a 12-inch or 15-inch diameter pump vaults or 30- inch when used in a duplex application. Risers shall be color coded green and must be certified to meet classifications CSA B182.4 and ASTM F794 for ribbed gravity sewer pipe and fittings, similar to Ipex Inc.'s Ultra-Rib riser material. Attach to watertight, flexible rubber grommets, cast-in-place riser adapter ring with adhesive, each end. Riser installation shall be accomplished according to the manufacturer's instructions.
 - ii. The riser and lid combination shall be able to support a 12,000 lb wheel load in all weather conditions, H10 rating with a baked urethane finish for positive UV protection and a hard, durable surface color-coded green. (Note: This is not to imply that PVC risers are intended for traffic areas).

EFFLUENT TANKS

- b. Gas Seals:
 - i. All conduit entering risers or meter boxes through grommets shall be sealed with cord grips (gas seals) to ensure that sewer gasses do not travel through conduit raceway into control panel causing corrosion.
 - ii. Gas seals are to have Acme threads on body to prevent skipping, constructed of polyamide 6/6 nylon with TPE or Buna N sealing gland, with a working temperature of -22°F (-30°C) to 212°F (100°C), with a protection class IP 68 per DIN 40050 up to 75 psi (5 bar) water pressure, and suitable for NEMA type 4 and 6 enclosures.
- c. Grommets:
 - i. Rubber Grommets are required for any riser penetrations. Grommets are to have two flanges with a smaller diameter flange on one side, which facilitates easy insertion, made of Neoprene rubber or similar material, and color coded black. Applications include Electrical Insulation, Sealing, Noise Control, and Vibration Isolation. Only proven, watertight grommets will be accepted.
- d. Adhesive:
 - i. Two-part epoxies shall be such as WELD-ON 810 (A & B) KIT WHITE, a two-component, high strength, reactive adhesive for joining, fabricating, and repairing PVC and CPVC fittings.
 - a) Must have a Brookfield Viscosity at minimum 40,000 cps @ 73 ± 3.6°F and max VOC emissions of 75 G/L, per SCAQMD Rule 1168, Method 361A.
 - b) Caulk-style adhesives shall have a tear propagation resistance of 7 MPa, a tensile strength at break of approximately 1.4 MPa, an elastic recovery of >90%, and a tensile strength of 0.5 MPa approx. @ 50% elongation (20°C), such as Sikaflex-11FC.

EFFLUENT TANKS

- c) Use one pint of the epoxy per riser, for bonding riser to adapter rings. Use one quart of the epoxy for a 30- inch diameter riser.
 - e. Flexible Adapter Boots: All inlet and outlet openings in the tanks must contain flexible adapter boots. A stainless-steel clamp is required with the boots.
 - f. Riser Lids: Riser lids shall be furnished with each riser.
 - i. Riser lids shall be fiberglass, unless under pavement. They shall be constructed of heavy-duty fiberglass and must contain a soft gasket to provide a 100% waterproof seal in all conditions at all times.
 - ii. Riser lids in pavement areas shall be cast iron with green nonskid finish, and provided with elastomeric gasket, stainless steel bolts, and wench.
 - g. Inspection port: 2-inch inspection port with watertight polypropylene lid.
 - h. Resilient Connectors: Inlets shall be fitted with seals that meet or exceed all ASTM C specifications.
- 9. Inlet plumbing shall penetrate 18 inches into the liquid from the inlet flow line.
- 10. Pump Vaults
 - a. Pump vaults shall house the pump. Vaults shall consist of a pump enclosure, an effluent filter that screens gray water before pumping made of 1/8" polypropylene filter mesh encapsulated in urethane caps (or similar filter tube material), a bracket to hang a float tree, and PVC handles that allow the filter to hang on the rim at the opening in the tank. Filters shall be as that of STEPros HFSCV45MF12, or an approved equal.

EFFLUENT TANKS

- F. Testing: In order to demonstrate water tightness, tanks shall be tested twice prior to acceptance. Each tank shall be tested at the factory, prior to shipping, by filling to two (2) inches above the top of the lid and the exfiltration rate shall be determined by measuring the water loss during the next twenty-four hours. The same test will be conducted once the tank is in the field, prior to backfilling. Any visual leaks or wetness on the outside of the tank shall be cause for failure. Minor imperfections may be corrected after installation.

2.2 CONCRETE SEPTIC TANKS (STEG and STEP)

- A. Septic tanks shall meet all the requirements of Part 2.1 above.
- B. Capacity and Characteristics:
1. Capacity: 1,500 gallons, for single-family homes and larger as appropriate for commercial installations.
 2. Inlet: 3 or 4-inch NPS per local code.
 3. Septic tanks shall be concrete (or fiberglass reinforced plastic (FRP), if approved).
- C. For residential service, one tank per structure is required, i.e. no sharing of tanks.
- D. List of approved manufacturers:
1. C.R. Barger & Sons, Inc.
 2. Jarrett Concrete Products & Supply Inc.
 3. Wells Septic Tanks
 4. Mitchell Concrete Tanks

2.3 FINAL DOSING & RECIRCULATION TANKS

- A. Dosing tanks shall meet all the requirements of Part 2.1 above.
- B. Design: For effluent pump installation.
1. Risers: 20-inch-minimum diameter opening with 30-inch risers to grade and access lid with steel lift rings. Include riser at pumps locations, and other locations as shown on the project drawings. Include riser in center of each tank compartment top.
 2. Capacity and Characteristics:
 - a. Capacity: Size to be determined by the number of pumps and the total storage volume required. Minimum size: 2000 gallons.

22 13 53

EFFLUENT TANKS

- b. Inlet and Outlet Size: as shown on the project drawings.

END OF SECTION 22 13 53

PART 1 - GENERAL

1.1 RELATED DOCUMENTS

- A. Drawings and general provisions of the Contract.
- B. Related Sections:
 - 1. 13 15 16 CONTROL BUILDING
 - 2. 22 13 43 EFFLUENT PUMPS
 - 3. 32 84 13 EFFLUENT DRIP DISPERSAL

1.2 SECTION INCLUDES

- A. Grounding and bonding equipment.
- B. Grounding rods.
- C. Bare conductors.
- D. Bus bar.
- E. Single conductor insulated wire.
- F. Terminal lugs.
- G. Jumpers.

1.3 REFERENCES

- A. American Society for Testing and Materials (ASTM):
 - 1. ASTM B3 Specification for Soft or Annealed Copper Wire
 - 2. ASTM B187 Specification for Copper Bar, Bus Bar, Rod and Shapes
- B. Institute of Electrical and Electronics Engineers (IEEE):
 - 1. IEEE 837 Qualifying Permanent Connections Used in Substation Grounding
 - 2. IEEE 142 IEEE Recommended Practice for Grounding of Industrial and Commercial Power Systems
- C. Underwriters Laboratories Inc. (UL):
 - 1. UL 467 Grounding and Bonding Equipment
- E. National Fire Protection Association (NFPA) Standards
 - 1. NFPA 70 National Electrical Code
 - 2. NFPA 780 Standard for the Installation of Lightning Protection Systems.

1.4 REGULATORY REQUIREMENTS

- A. Shop Drawings:
 - 1. Submit Shop Drawings showing locations of ground rods, grounding connections, locations of embedded and buried grounding conductors, and locations of stubouts and pigtails

for future connections to the grounding system by others. Drawings shall also indicate locations of test points to measure grounding resistance.

- B. Submit Shop Drawings showing electrical systems and equipment grounding and bonding connection schematic diagrams.
- C. Submit grounding design calculations to meet the requirement of Article 2.02.
- D. Product Data: Submit manufacturers' product data of manufactured materials.
- E. Test Reports: Submit copies of certified test reports of grounding resistance tests, including method of measurement.

1.5 DELIVERY, STORAGE AND HANDLING

- A. Provide marking on wire and cable in accordance with applicable standards. Each item shall be UL-labeled.
- B. Ship each item of equipment and materials securely wrapped, packaged, and labeled for safe handling in shipment and to avoid damage.
 - 1. Store equipment and materials in secure and dry storage facility.

PART 2 - PRODUCTS

2.1 EQUIPMENT AND MATERIALS

- A. Grounding and Bonding Equipment: Conform to UL 467 and the additional requirements specified herein.
- B. Ground Rods: Medium carbon steel core, copper-clad by the molten weld casting process, size of 1"x10'- 0" (one inch diameter by ten feet) long or as indicated, UL listed.
- C. Bare Conductors: ASTM B3, Class B stranded, annealed copper conductor, unless otherwise indicated, size as indicated.
- D. Bus Bar: ASTM B187, 98 percent conductivity copper, size as indicated.
- E. Single Conductor Insulated Wire: Use insulated ground wire for grounding communication and train control systems.
- F. Jumpers: Tin-plated copper, braided, flexible jumper.

2.2 GROUNDING DESIGN

- A. Unless otherwise indicated, total ground resistance shall not exceed 5Ω.
- B. In control room the resistance from the equipment rack to ground plate and from wayside devices to system ground shall not exceed 0.5Ω.

PART 3 - EXECUTION

3.1 INSTALLATION OF GROUNDING SYSTEM

A. Ground Connections:

1. Provide exothermically welded or compression-type terminal lugs for buried or embedded connections using materials qualified in accordance with IEEE 837. Bolted connections shall not be buried or embedded. For compression-type connectors, the tool for crimping shall emboss the die index number into the connector as the crimp is completed. Each compression-type connector shall have an inspection port for use in checking proper conductor insertion.
2. All connections shall be made in accordance with the manufacturer's requirements. All connections shall be cleaned and coated with a bitumastic epoxy before backfilling.
3. Above ground connections shall be made using materials qualified in accordance with IEEE 837. All connections shall be made in accordance with the National Electrical Code and the manufacturer's recommendations.
4. Provide continuous ground conductor or splice using connections qualified in accordance with IEEE 837. All splice connections shall be made in accordance with the manufacturer's requirements.
5. Connect the bus bar to station ground system as indicated. Provide waterstops on ground cable risers, where the risers enter the structure.

B. Ground Rods:

1. Bury ground rods vertically with rod top a minimum of two feet below grade as indicated. Use ground rod as indicated for main grounding system. If extensive rock formation is encountered, relocate ground rods to a new location as approved by the Engineer.
2. Interconnect ground rods with minimum 250 kcmil stranded bare copper cable or as indicated.
3. Ground the frames of motors larger than 25 hp by a ground conductor carried in the power conduit. Provide a ground conductor sized in accordance with the National Electrical Code.
4. Ground the non-current-carrying metal enclosures of transformers with a conductor sized as indicated or as required by the National Electrical Code.

5. To minimize interference between adjacent rods, the minimum inter-rod distance shall not be less than two rod lengths.
- A. Grounding Wires: All grounding wires shall be as indicated and sized to provide adequate conduction path for all possible faults and electrical interference currents.
- B. Grounding Requirements: Provide separate systems and equipment grounding as indicated.
- C. Ground metallic conduits, raceways, under-floor ducts, cable trays, boxes, cabinets, exposed expansion joints, lighting fixtures, and receptacles in accordance with the National Electrical Code.

3.2 FIELD QUALITY CONTROL

- A. Ground Resistance:
 1. Test the grounding system by the fall-of-potential method under the observation of the Owner. Ground resistance measurement test shall be made in normally dry conditions not less than 48 hours after the last rainfall. If the test is influenced by nearby ground grid, then the test shall be repeated by locating reference electrode to a longer distance until interference is minimized.
 2. Each ground rod shall be tested individually per latest NEC requirements before connecting them together to make grid. Grid ground resistance shall be tested to verify it meets the grounding requirements.
 3. Unless otherwise indicated, demonstrate that total ground resistance does not exceed 5Ω .
 4. The ground resistance shall not exceed 0.5Ω as measured from equipment racks to ground plate in train control rooms and from wayside devices to system ground bus or ground rod connection.
 5. To meet these resistance requirements, bury additional ground rods or use electrolytic grounding electrodes, or soldier piles as grounding conductors.
- B. Ground System Continuity: Test equipment enclosures, conduit, raceways, exposed expansion joints, lighting fixtures, receptacles, light standards, and metal fencing for continuity to the ground system.

END OF SECTION 26 05 26

PART 1 GENERAL

1.1 RELATED DOCUMENTS

- A. The work shall be installed complete in accordance with plans and specifications and left in proper operating condition.
- B. 13 15 16 CONTROL BUILDING
- C. 22 13 43 EFFLUENT PUMPS
- D. 26 05 26 GROUNDING AND BONDING FOR ELECTRICAL SYSTEMS
- E. 32 84 13 DRIP DISPERSAL

1.2 SUMMARY

- A. This Section includes electrical wiring for effluent pumps, control valves, control panels, Control Building features.
- B. Electrical work to be in accordance with all applicable codes and authorities. New materials to have Underwriters Labels where applicable. CONTRACTOR shall obtain all necessary permits and inspections and pay all fees involved.
- C. Provide all electrical conduits, circuits, and connections for all items as indicated, or specified, including line voltage control wiring.
- D. Provide all electrical material and equipment indicated or needed. Provide disconnect safety switches where needed or required. Provide manual motor switches for small motors unless furnished with motor.
- E. Arrange for and provide temporary lighting and electrical services necessary for the construction of this project.

1.3 SUBMITTALS

- A. Provide three (3) copies of shop drawings for all equipment to EDGE for approval.
- B. Substitutions shall be equal in performance. Proposed substitutions shall be submitted with sufficient time for consideration. No substitution shall be made without prior approval. Items not specifically identified by type of catalog number shall be proper type for this installation, of good quality, and in accordance with accepted standards. Submit shop drawings for panelboards.
- C. Proposed substitutions shall state the item for which they are to substitute. Such proposed substitutions shall indicate how the item(s) are equivalent or superior.

1.4 QUALITY ASSURANCE

- A. Maintain code-required clearances around all electrical equipment. Coordinate installation with structural features and piping locations.

PART 2 PRODUCTS

- 2.1 All items indicated shall be new, unless otherwise noted.
- 2.2 WIRING
- A. Wire shall be copper with type TW or THWN insulation for #12 and #10 sizes and type THW and THWN insulation for larger sizes. Minimum size conductor to be #14 unless otherwise noted. Wire sized #8 or larger and control wire shall be stranded. Control wire shall be type THWN, size #14 AWG, or as recommended by the equipment manufacturer. Fixture wiring shall be as required by code. Direct bury cable to be copper Type UF or other cable material rated for that application.
- 2.3 CONDUITS
- A. Install all building power wiring in rigid metal or PVC electrical conduit except wiring from thermostat to fan may be flexible metal conduit. Conduits, fittings, and boxes shall be steel, I.M.C., rigid galvanized or E.M.T. as required. E.M.T. may only be used inside the building where acceptable by the Electrical Codes and applicable authorities.
- B. Exposed conduit shall be installed parallel to building lines.
- C. Underground conduits may be Schedule 40 PVC, minimum twenty-four inches (24") underground, or in concrete. Otherwise, use rigid galvanized steel conduit with PVC coating.
- D. Conduits left empty shall have fish wire.
- E. Minimum conduit size shall be $\frac{3}{4}$ ", except STEP tank at residence to control panel shall be $\frac{1}{2}$ " diameter.
- 2.4 PULL AND SPLICE BOXES
- A. Provide pull boxes in long conduit runs as necessary to limit pulling force as recommended by the manufacturer.
- B. In general, runs of more than 200 feet shall include a pull box.
- C. Pull and splice boxes for solenoid control wiring in the drip field shall be Raven Model RMB-11-18-18 with Sigma Model N1118GRNSEW ductile iron lid.
- D. Where pull and/or splice boxes are needed every 500 feet along collection system to a remote drip field, use Old Castle Box with same material lid as box (not ductile iron) that can be bolted down.
- 2.5 WALL SWITCHES
- A. Wall switches shall be AC general use snap switch with toggle handle, specification grade, 20 amp, 120-277 volts.

- B. Wall receptacles shall be specification grade with ivory plastic face. Duplex receptacles on dedicated circuits shall be NEMA type 5-20R.
- C. Wall cover plates shall be stamped steel with rounded corners.

2.6 RECEPTACLES

- A. Weatherproof receptacles shall have 5205WO covers, mounted horizontally.
- B. Other receptacles and devices shall be of equal quality to the series specified.

2.7 PHOTOCELLS

- A. Photocell control shall be Tork #3010, shielded from light fixture if necessary, all mounted raintight.

2.8 LIGHT FIXTURES

- A. Provide light fixtures complete with lamps as shown on the drawings.
- B. Substitutions shall be equal in performance and appearance.
- C. Provide proper mounting support.

2.9 PANELBOARDS

- A. Panelboards shall be in enclosing cabinets with doors and locks, all locks keyed the same.
- B. Panels to be as scheduled on the drawings, equal to Square D type "NEHB", "I Line", "QMB", or "NQOD" bolt-on as scheduled with typed directory mounted on door.
- C. Cabinets in Class III areas shall be dust proof.

2.10 GROUNDING

- A. Provide $\frac{3}{4}$ " x 10' copper clad ground rod for grounding main service.
- B. Also, ground main service to the water main.
- C. Use Cadweld or approved grounding clamps for connections.
- D. Use #4 copper ground wire from columns to ground rods to ground building structural steel.

2.11 RACEWAYS

- A. All interior raceways shall be galvanized electrical metallic tubing (EMT) equipped with steel set screw and box connectors.

2.12 LIGHTS

- A. All lights shall be LED type.

PART 3 EXECUTION

3.1 GENERAL

- A. All work shall be performed by craftsmen skilled in the particular trade involved.
- B. The installation shall be made in accordance with the best-accepted practices of the trade.
- C. The work shall be left complete, in proper working condition and with a clean and neat appearance.

3.2 SLEEVES, BRACES, AND SUPPORTS

- A. CONTRACTOR shall be responsible for necessary sleeves, supports, etc., for his installation as the work progresses.
- B. Provide proper unistrut type braces and supports where needed to mount electrical equipment.

3.3 CONDUITS AND BOXES

- A. Install overhead exposed conduit system at roof or on structural members.
- B. Conceal conduits and boxes in walls where possible.
- C. Conduits are to be concealed.

3.4 ELECTRICAL SERVICE

- A. Contact and cooperate with the local electric power distributor and arrange for proper services where indicated. Cover all charges involved.

3.5 CONCRETE ENCASEMENT

- A. PVC conduit under pavement shall be in 6" x 6" concrete encasement and center of conduit may be fifteen inches (15") below top of pavement.
- B. Use proper fittings to enter hand hole.

3.6 CONDUITS

- A. Metal conduits shall have steel couplings and fittings.
- B. PVC conduit shall have PVC solvent weld couplings and fittings.

3.7 TRANSFORMER MOUNTS

- A. Mount transformers on vibration isolators. Ground neutral of secondary side to cold water pipe and building steel.

3.8 DISCONNECT SWITCHES

- A. Disconnect switches shall be fusible or nonfusible, quick-break, load interrupter enclosed knife switch with externally operable handle interlocked to prevent opening front cover with switch in "ON" position.
- B. Disconnect switches shall be equal to General Electric or Square D.

3.9 DRIP ZONE SOLENOID CONTROL WIRING

- A. Drip zone solenoid control wiring shall be installed in a minimum 2-inch electrical conduit to the first zone in each drip field and thereafter shall be direct bury wire.
- B. Pull boxes for solenoid control wiring shall be installed at minimum 500 feet spacing, including control wiring to remote drip fields.

26 20 00

ELECTRICAL WORK, GENERAL

END OF SECTION 26 20 00

PART 1 GENERAL

1.1 RELATED DOCUMENTS

A. Drawings and general provisions of the Contract, including General and Supplementary Conditions and Division 01 Specification Sections, apply to this Section.

B. Related Sections:

1. 31 20 00 EARTH MOVING

1.2 SUMMARY

A. Section Includes:

1. Protecting existing vegetation to remain.
2. Removing existing vegetation.
3. Clearing and grubbing.
4. Stripping and stockpiling topsoil.
5. Stripping and stockpiling rock.
6. Removing above- and below-grade site improvements.
7. Disconnecting, capping or sealing, removing site utilities and abandoning site utilities in place.
8. Temporary erosion and sedimentation control.

1.3 DEFINITIONS

A. Subsoil: Soil beneath the level of subgrade; soil beneath the topsoil layers of a naturally occurring soil profile, typified by less than 1 percent organic matter and few soil organisms.

B. Surface Soil: Soil that is present at the top layer of the existing soil profile. In undisturbed areas, surface soil is typically called "topsoil," but in disturbed areas such as urban environments, the surface soil can be subsoil.

C. Topsoil: Top layer of the soil profile consisting of existing native surface topsoil or existing in-place surface soil; the zone where plant roots grow. Its appearance is generally friable, pervious, and black or a darker shade of brown, gray, or red than underlying subsoil; reasonably free of subsoil, clay lumps, gravel, and other objects larger than 2 inches in diameter; and free of weeds, roots, toxic materials, or other non-soil materials.

- D. Plant-Protection Zone: Area surrounding individual trees, groups of trees, shrubs, or other vegetation to be protected during construction and indicated on Drawings.
- E. Tree-Protection Zone: Area surrounding individual trees or groups of trees to be protected during construction and indicated on Drawings.
- F. Vegetation: Trees, shrubs, groundcovers, grass, and other plants.

1.4 PREINSTALLATION MEETINGS

- A. Preinstallation Conference: Conduct conference at Project site.

1.5 MATERIAL OWNERSHIP

- A. Except for materials indicated to be stockpiled or otherwise remain EDGE WASTEWATER (EDGE) property, cleared materials shall become Contractor's property and shall be removed from Project site.

1.6 INFORMATIONAL SUBMITTALS

- A. Existing Conditions: Documentation of existing trees and plantings, adjoining construction, and site improvements that establish preconstruction conditions that might be misconstrued as damage caused by site clearing.
 - 1. Use sufficiently detailed photographs or video recordings.
 - 2. Include plans and notations to indicate specific wounds and damage conditions of each tree or other plant designated to remain.
- B. Topsoil stripping and stockpiling program.
- C. Rock stockpiling program.
- D. Record Drawings: Identifying and accurately showing locations of capped utilities and other subsurface structural, electrical, and mechanical conditions.
- E. Burning: Documentation of compliance with burning requirements and permitting of authorities having jurisdiction. Identify location(s) and conditions under which burning will be performed.

1.7 QUALITY ASSURANCE

- A. Topsoil Stripping and Stockpiling Program: Prepare a written program to systematically demonstrate the ability of personnel to properly follow procedures and handle materials and equipment during the Work. Include dimensioned diagrams for placement and protection of stockpiles.
- B. Rock Stockpiling Program: Prepare a written program to systematically demonstrate the ability of personnel to properly follow procedures and handle materials and equipment during the Work. Include dimensioned diagrams for placement and protection of stockpiles.

1.8 FIELD CONDITIONS

- A. Traffic: Minimize interference with adjoining roads, streets, walks, and other adjacent occupied or used facilities during site-clearing operations.
 - 1. Do not close or obstruct streets, walks, or other adjacent occupied or used facilities without permission from EDGE and authorities having jurisdiction.
 - 2. Provide alternate routes around closed or obstructed trafficways if required by EDGE or authorities having jurisdiction.
- B. Improvements on Adjoining Property: Authority for performing site clearing indicated on property adjoining EDGE's property will be obtained by EDGE before award of Contract.
 - 1. Do not proceed with work on adjoining property until directed by EDGE.
- C. Salvageable Improvements: Carefully remove items indicated to be salvaged and store on EDGE's premises [where indicated].
- D. Utility Locator Service: Notify One Call utility locating service for area where Project is located before site clearing.
- E. Do not commence site clearing operations until temporary erosion- and sedimentation-control and plant-protection measures are in place.
- F. Tree- and Plant-Protection Zones: Protect trees and vegetation as indicated on the construction drawings.

- G. Soil Stripping, Handling, and Stockpiling: Perform only when the soil is dry or slightly moist.

PART 2 PRODUCTS

2.1 MATERIALS

- A. Satisfactory Soil Material: Requirements for satisfactory soil material are specified in Section 312000 "Earth Moving."
 - 1. Obtain approved borrow soil material off-site when satisfactory soil material is not available on-site.

PART 3 EXECUTION

3.1 PREPARATION

- A. Protect and maintain benchmarks and survey control points from disturbance during construction.
- B. Verify that trees, shrubs, and other vegetation to remain or to be relocated have been flagged and that protection zones have been identified and enclosed using 4-foot high orange snow/safety fence.
- C. Protect existing site improvements to remain from damage during construction.
 - 1. Restore damaged improvements to their original condition, as acceptable to EDGE.

3.2 TEMPORARY EROSION AND SEDIMENTATION CONTROL

- A. Provide temporary erosion- and sedimentation-control measures to prevent soil erosion and discharge of soil-bearing water runoff or airborne dust to adjacent properties and walkways, according to erosion- and sedimentation-control Drawings and requirements of authorities having jurisdiction.
- B. Verify that flows of water redirected from construction areas or generated by construction activity do not enter or cross protection zones.
- C. Inspect, maintain, and repair erosion- and sedimentation-control measures during construction until permanent vegetation has been established.

- D. Remove erosion and sedimentation controls; restore and stabilize areas disturbed during removal.

3.3 TREE AND PLANT PROTECTION

- A. Protect trees and plants remaining on-site using 4-foot high orange snow/safety fence.
- B. Repair or replace trees, shrubs, and other vegetation indicated to remain or be relocated that are damaged by construction operations.

3.4 EXISTING UTILITIES

- A. EDGE will arrange for disconnecting and sealing indicated utilities that serve existing structures before site clearing, when requested by Contractor.
 - 1. Verify that utilities have been disconnected and capped before proceeding with site clearing.
- B. Locate, identify, disconnect, and seal or cap utilities indicated to be removed, or abandoned in place.
 - 1. Arrange with utility companies to shut off indicated utilities.
 - 2. EDGE will arrange to shut off indicated utilities when requested by Contractor.
- C. Locate, identify, and disconnect utilities indicated to be abandoned in place.
- D. Interrupting Existing Utilities: Do not interrupt utilities serving facilities occupied by EDGE or others, unless permitted under the following conditions and then only after arranging to provide temporary utility services according to requirements indicated:
 - 1. Notify EDGE not less than two (2) days in advance of proposed utility interruptions.
 - 2. Do not proceed with utility interruptions without EDGE's written permission.
- E. Excavate for and remove underground utilities indicated to be removed.

3.5 CLEARING AND GRUBBING

- A. Remove obstructions, trees, shrubs, and other vegetation to permit installation of new construction.

SITE CLEARING

1. Do not remove trees, shrubs, and other vegetation indicated to remain or to be relocated.
 2. Stumps in drip area to be dug up and hole filled and compacted.
 3. Use only hand methods or air spade for grubbing within protection zones.
 4. Any tree grinding that produces chips to be removed off site at Contractor's expense.
- B. Fill depressions caused by clearing and grubbing operations with satisfactory soil material unless further excavation or earthwork is indicated.
1. Place fill material in horizontal layers not exceeding a loose depth of 8 inches and compact each layer to a density equal to adjacent original ground.

3.6 TOPSOIL STRIPPING

- A. Remove sod and grass before stripping topsoil.
- B. Strip topsoil to depth indicated on Drawings or Engineering Report in a manner to prevent intermingling with underlying subsoil or other waste materials.
1. Remove subsoil and non-soil materials from topsoil, including clay lumps, gravel, and other objects larger than 2 inches in diameter; trash, debris, weeds, roots, and other waste materials.
- C. Stockpile topsoil away from edge of excavations without intermixing with subsoil or other materials. Grade and shape stockpiles to drain surface water. Cover to prevent windblown dust and erosion by water.
1. Do not stockpile topsoil within protection zones.
 2. Dispose of surplus topsoil. Surplus topsoil is that which exceeds quantity indicated to be stockpiled or reused.
 3. Stockpile surplus topsoil to allow for respreading deeper topsoil.

3.7 STOCKPILING ROCK

- A. Remove from construction area naturally formed rocks that measure more than 1 foot across in least dimension. Do not include excavated or crushed rock.

SITE CLEARING

1. Separate or wash off non-rock materials from rocks, including soil, clay lumps, gravel, and other objects larger than 2 inches in diameter; trash, debris, weeds, roots, and other waste materials.
- B. Stockpile rock where indicated on Drawings away from edge of excavations without intermixing with other materials. Cover to prevent windblown debris from accumulating among rocks.
 1. Do not stockpile rock within protection zones.
 2. Dispose of surplus rock. Surplus rock is that which exceeds quantity indicated to be stockpiled or reused.
 3. Stockpile surplus rock to allow later use by the Contractor.

3.8 SITE IMPROVEMENTS

- A. Remove existing above- and below-grade improvements as indicated and necessary to facilitate new construction.
- B. Remove slabs, paving, curbs, gutters, and aggregate base as indicated.
 1. Unless existing full-depth joints coincide with line of demolition, neatly saw-cut along line of existing pavement to remain before removing adjacent existing pavement. Saw-cut faces vertically.
 2. Paint cut ends of steel reinforcement in concrete to remain with two coats of antirust coating, following coating manufacturer's written instructions. Keep paint off surfaces that will remain exposed.

3.9 DISPOSAL OF SURPLUS AND WASTE MATERIALS

- A. Remove surplus soil material, unsuitable topsoil, obstructions, demolished materials, waste materials including trash and debris, and legally dispose of them off EDGE's property.
- B. Burning trees, shrubs, and other vegetation waste is permitted according to burning requirements and permitting of authorities having jurisdiction. Control such burning to produce the least smoke or air pollutants and minimum annoyance to surrounding properties. Burning of other waste and debris is prohibited.

- C. Separate recyclable materials produced during site clearing from other nonrecyclable materials. Store or stockpile without intermixing with other materials and transport them to recycling facilities. Do not interfere with other Project work.

END OF SECTION 31 10 00

PART 1 GENERAL

1.1 RELATED DOCUMENTS

A. Drawings and general provisions of the Contract, including General and Supplementary Conditions and Division 01 Specification Sections, apply to this Section.

B. Related Sections:

1. 13 15 16 CONTROL BUILDING
2. 22 13 53 EFFLUENT TANKS
3. 31 10 00 SITE CLEARING

1.2 SUMMARY

A. Section Includes:

1. Excavating and filling for rough grading the Site.
2. Excavating and backfilling for treatment facility and tanks.
3. Soil materials.
4. Stone/Sand materials.
5. Bedding materials for pipes, conduits and treatment facilities.
6. Subsurface drainage backfill for trenches.
7. Excavating and backfilling trenches for utilities and pits for buried utility structures.

1.3 RELATED REQUIREMENTS:

A. Section 311000 "SITE CLEARING" for site stripping, grubbing, stripping and stockpiling topsoil, and removal of above- and below-grade improvements and utilities.

1.4 DEFINITIONS

A. Backfill: Soil material used to fill an excavation.

1. Initial Backfill: Backfill placed beside and over pipe in a trench, including haunches to support sides of pipe.
2. Final Backfill: Backfill placed over initial backfill to fill a trench.

B. Bedding Course:

1. Aggregate layer placed over the excavated subgrade in a trench before laying pipe.

C. Borrow Soil: Satisfactory soil imported from off-site for use as fill or backfill.

D. Drainage Course: Aggregate layer supporting the slab-on-grade that also minimizes upward capillary flow of pore water.

- E. Excavation: Removal of material encountered above subgrade elevations and to lines and dimensions indicated.
 - 1. Authorized Additional Excavation: Excavation below subgrade elevations or beyond indicated lines and dimensions as directed by EDGE.
 - 2. Unauthorized Excavation: Excavation below subgrade elevations or beyond indicated lines and dimensions without direction by EDGE. Unauthorized excavation, as well as remedial work directed by EDGE, shall be without additional compensation.
- F. Fill: Soil materials used to raise existing grades.
- G. Structures: Buildings, footings, foundations, slabs, tanks, mechanical and electrical appurtenances, or other man-made stationary features constructed above or below the ground surface.
- H. Subbase Course: Aggregate layer placed between the subgrade and base course for hot-mix asphalt pavement, or aggregate layer placed between the subgrade and a cement concrete pavement or a cement concrete or hot-mix asphalt walk.
- I. Subgrade: Uppermost surface of an excavation or the top surface of a fill or backfill immediately below subbase, drainage fill, drainage course, or topsoil materials.
- J. Utilities: On-site underground pipes, and conduits, as well as underground services within buildings.

1.5 PREEXCAVATION MEETINGS

- A. Preexcavation Conference: Conduct preexcavation conference at Project site.
- B. Review methods and procedures related to earthmoving, including, but not limited to, the following:
 - 1. Personnel and equipment needed to make progress and avoid delays.
 - 2. Coordination of Work with utility locator service.
 - 3. Coordination of Work and equipment movement with the locations of tree- and plant-protection zones.
 - 4. Extent of trenching by hand or with air spade.
 - 5. Field quality control.

1.6 ACTION SUBMITTALS

- A. Product Data: For each type of the following manufactured products required:
 - 1. Geotextiles.

2. PVC Liner.
3. Tracer wire.
4. Samples for Verification: For the following products, in sizes indicated below:
 1. Tracer wire: 12 inches (300 mm) long; of each color.

1.7 INFORMATIONAL SUBMITTALS

- A. Qualification Data: Qualified testing agency to send qualification to EDGE prior to starting work.
- B. Material Test Reports: For each on-site and borrow soil material proposed for fill and backfill.

1.8 QUALITY ASSURANCE

- A. Geotechnical Testing Agency Qualifications: Qualified according to ASTM E 329 and ASTM D 3740 for testing indicated.

1.9 FIELD CONDITIONS

- A. Traffic: Minimize interference with adjoining roads, streets, walks, and other adjacent occupied or used facilities during earth-moving operations.
- B. Do not close or obstruct streets, walks, or other adjacent occupied or used facilities without permission from EDGE and authorities having jurisdiction.
- C. Provide alternate routes around closed or obstructed traffic ways if required by EDGE or authorities having jurisdiction.
- D. Improvements on Adjoining Property: Authority for performing earth moving indicated on property adjoining EDGE's property will be obtained by EDGE before award of Contract.
- E. Do not proceed with work on adjoining property until directed by EDGE.
- F. Utility Locator Service: Notify utility locator service, "Tennessee One Call" for area where Project is located before beginning earth-moving operations.
- G. Do not commence earth-moving operations until temporary site fencing and erosion- and sedimentation-control measures specified in the approved construction drawings are in place.
- H. Do not commence earth-moving operations until plant-protection measures specified in the approved construction drawings are in place.
- I. The following practices are prohibited within protection zones:
 1. Storage of construction materials, debris, or excavated material.

2. Parking vehicles or equipment.
3. Erection of sheds or structures.
4. Impoundment of water.
5. Excavation or other digging unless otherwise indicated.
6. Attachment of signs to or wrapping materials around trees or plants unless otherwise indicated.

PART 2 PRODUCTS

2.1 SOIL MATERIALS

- A. General: Provide borrow soil materials when sufficient satisfactory soil materials are not available from excavations.
- B. Satisfactory Soils: Soil Classification Groups ML, CL, OL, MH, CH, and OH, according to ASTM D 2487, free of rock or gravel larger than 3 inches in any dimension, debris, waste, frozen materials, vegetation, and other deleterious matter.
- C. Impervious Fill: Clay (CH or CL) capable of compacting to a dense state.

2.2 STONE/SAND MATERIALS

- A. Subbase Material: Naturally or artificially graded mixture of natural or crushed gravel, crushed stone, and natural or crushed sand; ASTM D 2940; with at least 90 percent passing a 1-1/2-inch sieve and not more than 12 percent passing a No. 200 sieve, or as shown on the approved construction drawings.
- B. Base Course: Naturally or artificially graded mixture of natural or crushed gravel, crushed stone, and natural or crushed sand; ASTM D 294; with at least 95 percent passing a 1-1/2-inch sieve and not more than 8 percent passing a No. 200 sieve, or as shown on the approved construction drawings.
- C. Engineered Fill: Naturally or artificially graded mixture of natural or crushed gravel, crushed stone, and natural or crushed sand; ASTM D 2940; with at least 90 percent passing a 1-1/2-inch sieve and not more than 12 percent passing a No. 200 sieve, or as shown on the approved construction drawings.
- D. Bedding Course: Naturally or artificially graded mixture of natural or crushed gravel, crushed stone, and natural or crushed sand; ASTM D 2940; except with 100 percent passing a 1-inch sieve and not more than 8 percent passing a No. 200 sieve, or as shown on the approved construction drawings.

- E. Drainage Course: Narrowly graded mixture of washed crushed stone, or uncrushed gravel; ASTM D 448; coarse-aggregate grading Size 57; with 100 percent passing a 1-1/2-inch sieve and zero to 5 percent passing a No. 8 sieve.
- F. Sand: ASTM C 33; washed fine aggregate.

2.3 ACCESSORIES

- A. Tracer Wire
 - 1. Tracer wire (detector wire, toning wire) shall be #14 (minimum) AWG, PVC coated solid copper wire (green color).

PART 3 EXECUTION

3.1 PREPARATION

- A. Protect structures, utilities, sidewalks, pavements, and other facilities from damage caused by settlement, lateral movement, undermining, washout, and other hazards created by earth-moving operations.
- B. Protect and maintain erosion and sedimentation controls during earth-moving operations.
- C. Protect subgrades and foundation soils from freezing temperatures and frost. Remove temporary protection before placing subsequent materials.

3.2 DEWATERING

- A. Prevent surface water and ground water from entering excavations, from ponding on prepared subgrades, and from flooding Project site and surrounding area.
- B. Protect subgrades from softening, undermining, washout, and damage by rain or water accumulation.
- C. Reroute surface water runoff away from excavated areas. Do not allow water to accumulate in excavations. Do not use excavated trenches as temporary drainage ditches.

3.3 EXPLOSIVES

- A. Explosives: Do not use explosives.

3.4 EXCAVATION, GENERAL

- A. Unclassified Excavation: Excavate to subgrade elevations regardless of the character of surface and subsurface conditions encountered. Unclassified excavated materials may include rock, soil materials, and obstructions. No changes in the Contract Sum or the Contract Time will be authorized for rock excavation or removal of obstructions.

3.5 EXCAVATION FOR STRUCTURES

- A. Excavate to indicated elevations and dimensions within a tolerance of plus or minus 0.1 ft. If applicable, extend excavations a sufficient distance from structures for placing and removing concrete formwork, for installing services and other construction, and for inspections.
- B. Excavation for Underground Tanks, Basins, and Mechanical or Electrical Utility Structures: Excavate to elevations and dimensions indicated within a tolerance of plus or minus 0.1 ft. Do not disturb bottom of excavations intended as bearing surfaces.
- C. Excavations at Edges of Tree- and Plant-Protection Zones:
 - 1. Excavate by hand or with an air spade to indicated lines, cross sections, elevations, and subgrades. If excavating by hand, use narrow-tine spading forks to comb soil and expose roots. Do not break, tear, or chop exposed roots. Do not use mechanical equipment that rips, tears, or pulls roots.

3.6 EXCAVATION FOR UTILITY TRENCHES

- A. Excavate trenches to indicated gradients, lines, depths, and elevations.
- B. Excavate trenches to uniform widths to provide the following clearance on each side of pipe or conduit. Excavate trench walls vertically from trench bottom to 12 inches higher than top of pipe or conduit unless otherwise indicated.
- C. Clearance: Trench to be at a minimum 12-inches wide or 3 times the pipe diameter, whichever is greater.
- D. Comply with EDGE's Drawing Numbers 03 and 04 for typical trench details.
- E. Trench Bottoms: Excavate and shape trench bottoms to provide uniform bearing and support of pipes and conduit. Shape subgrade to provide continuous support for bells, joints, and barrels of pipes and for joints, fittings, and bodies of conduits. Remove projecting stones and sharp objects along trench subgrade.

1. For pipes and conduit less than 6 inches in nominal diameter, hand-excavate trench bottoms and support pipe and conduit on an undisturbed subgrade.
 2. For flat-bottomed, multiple-duct conduit units, hand-excavate trench bottoms and support conduit on an undisturbed subgrade.
- F. Excavate soft spots, unsatisfactory soils, and areas of excessive pumping or rutting, as determined by EDGE or Geotechnical Engineer, and replace with compacted backfill or fill as directed.
- G. Reconstruct subgrades damaged by freezing temperatures, frost, rain, accumulated water, or construction activities, as directed by EDGE or Geotechnical Engineer, without additional compensation.
- 3.7 UNAUTHORIZED EXCAVATION
- A. Fill unauthorized excavations under pipe, or conduit as directed by EDGE or Geotechnical Engineer.
- 3.8 STORAGE OF SOIL MATERIALS
- A. Stockpile borrow soil materials and excavated satisfactory soil materials without intermixing. Place, grade, and shape stockpiles to drain surface water. Cover to prevent windblown dust.
- B. Stockpile soil materials away from edge of excavations. Do not store within drip line of remaining trees.
- 3.9 BACKFILL
- A. Place and compact backfill in excavations promptly, but not before completing the following:
1. Construction below finish grade including, where applicable.
 2. Surveying locations of underground utilities for Record Documents.
 3. Testing and inspecting underground utilities.
 4. Removing trash and debris.
 5. Removing temporary shoring, bracing, and sheeting.
 6. Installing permanent or temporary horizontal bracing on horizontally supported walls.
- B. Place backfill on subgrades free of mud, frost, snow, or ice.
- 3.10 UTILITY TRENCH BACKFILL
- A. Place backfill on subgrades free of mud, frost, snow, or ice.

- B. Place and compact bedding course on trench bottoms and where indicated. Shape bedding course to provide continuous support for bells, joints, and barrels of pipes and for joints, fittings, and bodies of conduits.
- C. Backfill voids with satisfactory soil while removing shoring and bracing.
- D. Initial Backfill:
 - 1. Soil Backfill: Place and compact initial backfill of subbase material, free of particles larger than 1 inch in any dimension, to a height of 12 inches over the pipe or conduit.
 - 2. Carefully compact initial backfill under pipe haunches and compact evenly up on both sides and along the full length of piping or conduit to avoid damage or displacement of piping or conduit. Coordinate backfilling with utilities testing.
- E. Soil Backfill: Place and compact final backfill of satisfactory soil to final subgrade elevation.
 - 1. Controlled Low-Strength Material: Place final backfill of controlled low-strength material to final subgrade elevation.
- F. Tracer wire:
 - 1. Tracer wire shall be taped to all pipes continuously, using waterproof silicone wire nuts where wires tie together.
 - 2. Loop tracer wire up to grade level at all risers, valve and meter boxes.

3.11 SOIL FILL

- A. Plow, scarify, bench, or break up sloped surfaces steeper than 1 vertical to 4 horizontal so fill material will bond with existing material.
- B. Place and compact fill material in layers to required elevations as follows:
 - 1. Under grass and planted areas, use satisfactory soil material.
 - 2. Under pavements, use satisfactory soil material.
 - 3. Under footings and foundations, use engineered fill.
 - 4. Place soil fill on subgrades free of mud, frost, snow, or ice.

3.12 SOIL MOISTURE CONTROL

- A. Uniformly moisten or aerate subgrade and each subsequent fill or backfill soil layer before compaction to within 2 percent of optimum moisture content.

- B. Do not place backfill or fill soil material on surfaces that are muddy, frozen, or contain frost or ice.
- C. Remove and replace, or scarify and air dry, otherwise satisfactory soil material that exceeds optimum moisture content by 2 percent and is too wet to compact to specified dry unit weight.

3.13 PROOF ROLL

- A. Upon excavating or filling to subgrade elevations, the contractor shall proof roll the subgrade.
- B. Completely proof-roll subgrade in one direction, repeating proof-rolling in direction perpendicular to first direction.
- C. Proof-roll subgrade below the treatment facility. Do not proof-roll wet or saturated subgrades.
- D. Areas found to have soft pockets or areas of excess yielding shall be excavated to firm, unyielding material. Such areas shall be backfilled to subgrade in accordance with subsection 3.14 below.

3.14 COMPACTION OF SOIL BACKFILLS AND FILLS

- A. Place backfill and fill soil materials in layers not more than 8 inches in loose depth for material compacted by heavy compaction equipment and not more than 4 inches in loose depth for material compacted by hand-operated tampers.
- B. Place backfill and fill soil materials evenly on all sides of structures to required elevations and uniformly along the full length of each structure.
- C. Compact soil materials to not less than the following percentages of maximum dry unit weight according to ASTM D 698:
 - 1. Under the treatment facility and pavements, scarify and recompact top 24 inches of existing subgrade and each layer of backfill or fill soil material at 95 percent.
 - 2. Under turf or unpaved areas, scarify and recompact top 6 inches below subgrade and compact each layer of backfill or fill soil material at 90 percent.
 - 3. For utility trenches, compact each layer of initial and final backfill soil material at 90 percent in turf or unpaved areas, and 95 percent in paved areas.
 - 4. Under pavement remove topsoil, scarify, and compact subgrade soil material at 95 percent.

3.15 GRADING

- A. General: Uniformly grade areas to a smooth surface, free of irregular surface changes. Comply with compaction requirements and grade to cross sections, lines, and elevations indicated.
 - 1. Provide a smooth transition between adjacent existing grades and new grades.
 - 2. Cut out soft spots, fill low spots, and trim high spots to comply with required surface tolerances.
- B. Site Rough Grading: Slope grades to direct water away from buildings and treatment facilities and to prevent ponding. Finish subgrades to elevations required to achieve indicated finish elevations, within the following subgrade tolerances:
 - 1. Turf or Unpaved Areas: Plus or minus .01 ft.
 - 2. Pavements: Plus or minus 0.05 ft.
 - 3. Grading treatment facilities: Finish subgrade to a tolerance of 0.05 ft when tested with a 10-foot straightedge.

3.16 SUBBASE AND BASE COURSES UNDER PAVEMENTS AND WALKS

- A. Place subbase course on subgrades free of mud, frost, snow, or ice.
- B. On prepared subgrade, place subbase course under pavements and walks as follows:
 - 1. Place base course material over subbase course under hot-mix asphalt pavement.
 - 2. Shape subbase course to required crown elevations and cross-slope grades.
 - 3. Compact subbase course at optimum moisture content to required grades, lines, cross sections, and thickness to not less than 95 percent of maximum dry unit weight according to ASTM D 698.

3.17 DRAINAGE COURSE UNDER CONCRETE SLABS-ON-GRADE

- A. Place drainage course on subgrades free of mud, frost, snow, or ice.
- B. On prepared subgrade, place and compact drainage course under cast-in-place concrete slabs-on-grade as follows:
 - 1. Place drainage course 6 inches or less in compacted thickness in a single layer.
 - 2. Compact each layer of drainage course to required cross sections and thicknesses to not less than 95 percent of maximum dry unit weight according to ASTM D 698.

3.18 PROTECTION

- A. Protecting Graded Areas: Protect newly graded areas from traffic, freezing, and erosion. Keep free of trash and debris.
- B. Repair and reestablish grades to specified tolerances where completed or partially completed surfaces become eroded, rutted, settled, or where they lose compaction due to subsequent construction operations or weather conditions.
 - 1. Scarify or remove and replace soil material to depth as directed by EDGE; reshape and recompact.
 - 2. Where settling occurs before Project correction period elapses, remove finished surfacing, backfill with additional soil material, compact, and reconstruct surfacing.
 - 3. Restore appearance, quality, and condition of finished surfacing to match adjacent work, and eliminate evidence of restoration to greatest extent possible.

3.19 DISPOSAL OF SURPLUS AND WASTE MATERIALS

- A. Remove surplus satisfactory soil and waste materials, including unsatisfactory soil, trash, and debris, and legally dispose of them off EDGE's property.
- B. Transport surplus satisfactory soil to designated storage areas on EDGE's property. Stockpile or spread soil as directed by EDGE.
- C. Remove waste materials, including unsatisfactory soil, trash, and debris, and legally dispose of them off EDGE's property.

31 20 00

EARTH MOVING

END OF SECTION 31 20 00

PART 1 GENERAL**1.1 RELATED DOCUMENTS**

- A. The work shall be installed complete in accordance with plans and specifications and left in proper operating condition.

1.2 SUMMARY

- A. This Section includes the following:
 - 1. High-tensile wire fencing,
 - 2. Fence posts,
 - 3. Bracing assemblies, and
 - 4. Gates.

1.3 SUBMITTALS

- A. Shop Drawings: For each type of product.
 - 1. Include construction details, material descriptions, and dimensions of individual components and profiles:
 - a. Fence and gate posts, rails, and fittings.
 - b. Gates and hardware.
- B. Provide three (3) copies of shop drawings for all equipment to EDGE for approval.
- C. Substitutions shall be equal in performance. Proposed substitutions shall be submitted with sufficient time for consideration. No substitution shall be made without prior approval.
- D. Include accessories, hardware, and operational clearances.

1.4 PREINSTALLATION MEETINGS

- A. Preinstallation Conference: Conduct conference at Project site.

PART 2 PRODUCTS**2.1 FENCING WIRE**

- A. High tensile wiring fencing shall meeting the following requirements:
 - 1. Class 3 Galvanized,
 - 2. 12.5 gauge,
 - 3. 170,000 to 200,000 psi hi-tensile wire, and
 - 4. Breaking strength greater than or equal to 1,800 pounds.

2.2 WOODEN FENCE POSTS

- A. Corner and gate posts should have a diameter of at least 8 inches,

- B. Brace posts should be 5-inches or more in diameter, and
- C. Line posts can be as small as 4 inches.
- D. All posts shall be pressure treated pine with chromated copper arsenate.

2.3 GATES

- A. Gates shall be 50 in. high, 12-feet wide, 6-bar steel tube gate, with vertical Z braces, constructed of 1-3/4-inch high tensile strength tubing. The gate shall be corrosion resistant and be of steel tube construction with powder-coating finish. The gate's hardware shall be included.

PART 3 EXECUTION

3.1 WOODEN FENCE POSTS

- A. Fence posts can be driven in the ground or dug into place.
 - 1. Line posts shall be placed 3 feet into the ground.
 - 2. Driven Posts: Posts larger than 4 inches may need to be sharpened to a dull point or driven in an auger-drilled pilot hole when using a post driver. Drive the post in the ground with a manual post-hole driver or a tractor type.
 - 3. Dug Posts: Dig the hole three times larger than the post diameter or width. Place the post in the hole and fill with ready mix concrete. Center the post in the hole before tamping.
 - 4. Plumb the post while tamping to see that it is in proper alignment.
 - 5. The distance between line posts depends primarily on topography. On extremely flat land, line posts are generally spaced from 10 to 16 feet apart.
 - 6. Maximum line post spacing: 40 to 60-feet.
 - 7. Install battens or spacers in all dips or at a maximum of 30 feet apart for five strands and 50 feet for two to three strands.
 - 8. Move line posts closer together as the terrain goes from flat to steep.
- B. Corner, End, and Line Brace Assemblies
 - 1. Corner Brace Assembly
 - a. The corner post will need a brace assembly for each fence leading to it.
 - 2. Double brace assembly

FENCING

- a. When the fence is more than 200 feet long, use a double brace assembly.
 - b. Set the corner posts leaning back from the direction of the fence approximately five degrees.
 - c. Brace wire should pull in the opposite direction than the fence is pulling.
3. Brace assembly
- a. When a fence is more than 650 feet between corner posts, use braced line post assemblies every 650 feet in the fence line.
 - i. A braced line assembly is the same as a single span braced corner, except a second diagonal brace wire is used to take fence pull in the opposite direction.
 - ii. In some situations, such as where adequate post depth cannot be achieved, additional bracing may be required to maintain tension.
 - b. Construct brace assemblies at proposed gate locations.

3.2 WIRE FENCING

- A. High-tensile wire shall be used to provide a 4-stran, 4-foot-high fence.
- 1. Wires can be run from the coil, one wire at a time, using a payout spinner, or
 - 2. Wires can be run several at a time using a multi-wire fencer.
 - 3. When walking from the far corner post to the first one, make sure the wires are in a straight line. Set points on line as necessary.
 - 4. Run the bottom wire out first and tension it sufficiently as a guide for setting line posts.
 - 5. Secure wires to corner, end or gate posts with crimping sleeves or appropriate knots. Secure the bottom wire to each line post as it is driven to assist in determining the next post position.
 - 6. String the wires on the inside of the posts or on the outside of curves.
 - 7. Drive staples slightly off the vertical so they straddle the wood grain. When driving staples into posts, rotate the staples around 25 degrees from the flat surface of the point.

FENCING

8. Drive staples at an upward angle into posts in dips, and at downward angles into posts on rises.
9. Do not drive staples in too deeply. The wire must be allowed to slide through the staples for adjusting tension.

B. Tensioning Wire

1. Tension each wire to 200 pounds with a ratchet inline strainer or tightener. Use a tension indicator spring to obtain the proper wire tension on each wire. Then, tighten all other wires by feel to match the tension on the wire with a spring.
2. On runs shorter than 600 feet, the in-line strainer and tension spring can be located anywhere along the fence, usually near one of the ends.
3. On long runs, place the in-line strainer and tension spring in the center of the fence so that the wire pulls in from both sides.
4. On long straight runs of more than 600 feet, place them at the friction center which is at the center point between the two corners or ends.
5. On long runs with a straight section on one end and several bends on the other, the friction center will be in the bends section rather than in the straight section.

3.3 GATES

- A. Locate gates for equipment and vehicle access at designated locations as shown on the approved construction plans.

END OF SECTION 32 31 13

PART 1 GENERAL

1.1 RELATED DOCUMENTS

- A. Drawings and general provisions of the Contract, including General and Supplementary Conditions apply to this Section.
- B. Related Sections:
 - 1. 01 33 16 DESIGN REQUIREMENTS
 - 2. 13 15 16 CONTROL BUILDING
 - 3. 22 13 13 EFFLUENT COLLECTION SYSTEM
 - 4. 22 13 43 EFFLUENT PUMPS
 - 5. 26 05 26 GROUNDING AND BONDING FOR ELECTRICAL SYSTEMS
 - 6. 26 20 00 ELECTRICAL WORK, GENERAL

1.2 SUMMARY

- A. Section Includes:
 - 1. Piping.
 - 2. Encasement for piping.
 - 3. Manual valves.
 - 4. Pressure-reducing valves.
 - 5. Automatic control valves.
 - 6. Automatic drain valves.
 - 7. Transition fittings.
 - 8. Miscellaneous piping specialties.
 - 9. Quick couplers.
 - 10. Drip irrigation specialties.
 - 11. Controllers.
 - 12. Boxes for automatic control valves.

1.3 DEFINITIONS

- A. Supply forcemain: Piping from final disposal chamber, through the control building, to the drip dispersal supply manifold.
- B. Supply manifold: Piping from the end of the supply forcemain up to the beginning of the drip emitter piping.
- C. Return forcemain: Piping from the return manifold to the recirculation tank.
- D. Return (flush) manifold: Piping from the end of the drip emitter piping to the return forcemain.

- E. Low Voltage: As defined in NFPA 70 for circuits and equipment operating at less than 50 V or for remote-control, signaling power-limited circuits.

1.4 PERFORMANCE REQUIREMENTS

- A. Irrigation zone control shall be automatic operation with controller and automatic control valves.
- B. Minimum Working Pressures: The following are minimum pressure requirements for piping, valves, and specialties unless otherwise indicated:
 - 1. Irrigation Main Piping: 150 psig.
 - 2. Circuit Piping: 150 psig.

1.5 ACTION SUBMITTALS

- A. Product Data: For each type of product indicated. Include rated capacities, operating characteristics, electrical characteristics, and furnished specialties and accessories.
- B. Wiring Diagrams: For power, signal, and control wiring.
- C. Delegated-Design Submittal: For irrigation systems indicated to comply with performance requirements and design criteria, including analysis data signed and sealed by the qualified professional engineer responsible for their preparation.

1.6 DESIGN INFORMATIONAL SUBMITTALS

- A. Coordination Drawings: Irrigation systems, drawn to scale, on which components are shown and coordinated with each other. Also include adjustments necessary to avoid unsuitable soils.
- B. Zoning Chart: Show each irrigation zone and its control valve.

1.7 CONTRACTOR INFORMATIONAL SUBMITTALS

- A. Qualification Data: For qualified Installer.
- B. Controller Timing Schedule: Indicate timing settings for each automatic controller zone.
- C. Field quality-control reports.

1.8 CLOSEOUT SUBMITTALS

- A. Operation and Maintenance Data: For drip irrigation tubing, controllers, and automatic control valves to include in operation and maintenance manuals.

1.9 QUALITY ASSURANCE

- A. Installer Qualifications: An employer of workers that include a certified installer by Tennessee Department of Environment & Conservation and has performed work in the Middle Tennessee Area within past five (5) years for drip installation and sanitary sewer forcemain collection pipes.
- B. Electrical Components, Devices, and Accessories: Listed and labeled as defined in NFPA 70, by a qualified testing agency, and marked for intended location and application.

1.10 DELIVERY, STORAGE, AND HANDLING

- A. Deliver piping with factory-applied end caps. Maintain end caps through shipping, storage, and handling to prevent pipe-end damage and to prevent entrance of dirt, debris, and moisture.
- B. Store plastic piping protected from direct sunlight. Support to prevent sagging and bending.

1.11 PROJECT CONDITIONS

- A. Interruption of existing utility service: Do not interrupt existing utility service to facilities occupied by EDGE or others unless permitted under the following conditions and then only after arranging to provide temporary service according to requirements indicated:
 - 1. Notify EDGE no fewer than 3 days in advance of proposed interruption of service.
 - 2. Do not proceed with interruption of utility service without EDGE's written permission.

PART 2 PRODUCTS

2.1 PIPES, TUBES, AND FITTINGS

- A. Drip irrigation piping shall have the following specifications:
 - 1. Drip irrigation tubing and fittings shall be as manufactured by Netafim Irrigation, Inc. or approved equal.
 - 2. Drip tubing for drip irrigation shall be "Bioline Dripperline" as manufactured by Netafim Irrigation, Inc. or approved equal.
 - 3. Drip-irrigation piping shall be 0.56 inch I.D.
 - 4. Tubing material: Linear low-density polyethylene with pressure compensating, self-cleaning emitters located on two-foot centers.
 - 5. Emitter shall have a constant flow rate of 0.61 gph regardless of system pressure.
 - 6. When dosing, system pressure shall be between 7 psi and 50 psi and shall be resistant to plant root intrusion.

EFFLUENT DRIP DISPERSAL

7. Tubing color: Purple.
 8. UV resistant.
 9. Recommended filtration: 120 mesh.
 10. Bending radius: 7".
 11. Drippers shall be anti-bacterial-impregnated to prevent buildup of microbial slime.
 12. IPS Flexible vinyl pipe shall be used for:
 - a. Connecting supply and return manifolds to drip emitter piping,
 - b. Making flexible swing joints,
 - c. To repair breaks in rigid PVC pipe, and
 - d. As a tightline to easily get around, under or over obstacles.
- B. Drip-irrigation fittings shall meet the following requirements:
1. Barbed fittings for a secure fit.
 2. Easy installation without glue or tools.
 3. Allows for easy on-site inspection of proper fitting installation.
- C. Supply and return (flushing) manifold piping
1. Piping for drip field supply line and flush return line shall be SDR 17 PVC, unless approved otherwise in writing by the EDGE.
 2. Piping for drip field supply and return (flushing) manifolds shall be Schedule 40 PVC. DWV pipe is not allowed.
 3. Pipe shall be light purple in color.
 4. Fittings for piping including unions, tees, and bends shall be constructed of minimum Schedule 40 PVC.

2.2 VALVES

- A. Isolation Ball Valves
1. Isolation ball valves up to 2" shall be constructed of Schedule 40 PVC glue in. Stem seal shall be constructed of EPDM and ball shall be HMW-HDPE. Valves shall be of low-torque design and rated for 150 psi working pressure. Valves shall open to the left.
- B. Ball Check Valves

EFFLUENT DRIP DISPERSAL

1. Ball check valves up to 2" shall be constructed of Schedule 80 PVC or UPVC plastic and be true-union. No more than 3 psi (horizontal or vertical) shall be required for closure. O-rings shall be constructed of EPDM. Check valves shall be rated for 150 psi working pressure.
- C. Air Release and Air/Vacuum Valves
1. Air release and air/vacuum valves shall be of plastic / fiberglass construction suitable for 150 psi working pressure. Resilient automatic valve seal shall provide smooth positive opening, closing, and leak free sealing over a wide range of pressure differentials. Air release valve on the drip field supply line shall be $\frac{3}{4}$ ". Air/vacuum valves in the drip field shall be plastic body, button-type, with Buna-N seal, $\frac{1}{2}$ ".
- D. Solenoid Control Valves
1. Solenoid control valve for flow through the disc filters shall utilize the double-chambered actuator and a three-way brass, 24V AC, 1/8" solenoid to alternately apply upstream pressure to the upper control chamber to close and vent to drain to open.
 2. Solenoid control valves for flow to each drip field shall be on/off two-way, globe type, nylon reinforced plastic, 24V AC solenoid.
- Pressure Reducing Valves
3. Pressure reducing valves to be adjustable, direct acting, cavitation and surge resistant, constructed of high impact thermoplastics and maintain a constant outlet pressure.
- E. Combination Flow Meter/Hydraulic Valve
1. Meter/valve shall consist of a turbine type water meter and a diaphragm actuated solenoid control valve in a single epoxy-coated cast iron body. Automatically opens and closes in response to a 24V DC electrical signal. Output signal shall be 4-20 mA. Meter uses a gear mechanism, which activates a reed switch to transmit a pulse at a pre-determined flow.

2.3 VALVE BOXES

- A. Valve boxes for buried service shall be 18" x 11" plastic meter box sections. Valve box lids shall be constructed of plastic with a non-skid finish and labeled "Sewer".

PART 3 EXECUTION

3.1 PREPARATION

- A. Set stakes to identify locations of proposed irrigation system. Obtain EDGE'S approval before installing each drip zone.

3.2 EARTHWORK

- A. Excavating, trenching, and backfilling are specified in Section 31 20 00 Earth Moving.

3.3 PROTECTION OF DRIP DISPERSAL AREA

- A. The drip dispersal area shall be clearly marked and protected from other construction activities. Use of the area for activities such as ingress or egress, or storage of materials may invalidate the site for use as a drip dispersal area.
- B. Site should be mowed and cleared of brush and small trees that are not part of the landscaping plan. Clearing is to be accomplished with minimal digging or grubbing. Large trees, boulders or other obstacles should be bypassed and left as part of the landscape, unless otherwise indicated.
- C. No work shall be done in the drip dispersal area when the soil is wet enough to easily compact.

3.4 PIPING INSTALLATION

- A. Location and Arrangement: Drawings indicate location and arrangement of piping systems. Install piping as indicated unless deviations are approved on Coordination Drawings.
- B. Install piping at minimum uniform slope of 0.5 percent down toward drain valves.
- C. Install piping free of sags and bends.
- D. Install groups of pipes parallel to each other, spaced to permit valve servicing.
- E. Install fittings for changes in direction and branch connections.
- F. Install unions adjacent to valves and to final connections to other components with NPS 2 or smaller pipe connection.
- G. Install flanges adjacent to valves and to final connections to other components with NPS 2-1/2 or larger pipe connection.
- H. Lay piping on solid subbase, uniformly sloped without humps or depressions.
- I. Install PVC piping in dry weather when temperature is above 40 deg F. Allow joints to cure at least 24 hours at temperatures above 40 deg F before testing.
- J. Install piping in sleeves under parking lots, roadways, and sidewalks.

- K. Install sleeves made of SDR 17 PVC pipe and socket fittings, and solvent-cemented joints.

3.5 JOINT CONSTRUCTION

- A. Ream ends of pipes and tubes and remove burrs. Bevel plain ends of pipe.
- B. Remove scale, slag, dirt, and debris from inside and outside of pipe and fittings before assembly.
- C. Threaded Joints: Thread pipe with tapered pipe threads according to ASME B1.20.1. Cut threads full and clean using sharp dies. Ream threaded pipe ends to remove burrs and restore full ID. Join pipe fittings and valves as follows:
 - 1. Apply appropriate tape or thread compound to external pipe threads unless dry seal threading is specified.
 - 2. Damaged Threads: Do not use pipe or pipe fittings with threads that are corroded or damaged. Do not use pipe sections that have cracked or open welds.
- D. Flanged Joints: Select rubber gasket material, size, type, and thickness for service application. Install gasket concentrically positioned. Use suitable lubricants on bolt threads.
- E. PE Piping Fastener Joints: Join with insert fittings and bands or fasteners according to piping manufacturer's written instructions.
- F. PE Piping Heat-Fusion Joints: Clean and dry joining surfaces by wiping with clean cloth or paper towels. Join according to ASTM D 2657.
 - 1. Plain-End PE Pipe and Fittings: Use butt fusion.
 - 2. Plain-End PE Pipe and Socket Fittings: Use socket fusion.
- G. PVC Piping Solvent-Cemented Joints: Clean and dry joining surfaces. Join pipe and fittings according to the following:
 - 1. Comply with ASTM F 402 for safe-handling practice of cleaners, primers, and solvent cements.
 - 2. PVC Pressure Piping: Join schedule number, ASTM D 1785, PVC pipe and PVC socket fittings according to ASTM D 2672. Join other-than-schedule-number PVC pipe and socket fittings according to ASTM D 2855.
 - 3. PVC Nonpressure Piping: Join according to ASTM D 2855.

3.6 VALVE INSTALLATION

- A. Isolate flow to fields using solenoid valves unless directed otherwise by the EDGE.
- B.

- C. Underground Curb Valves: Install in curb-valve casings with tops flush with grade.
- D. Underground Iron Gate Valves, Resilient Seat: Comply with AWWA C600 and AWWA M44. Install in valve casing with top flush with grade.
 - 1. Install valves and PVC pipe with restrained, gasketed joints.
- E. Aboveground Valves: Install as components of connected piping system.
- F. Pressure-Reducing Valves: Install in boxes for automatic control valves or aboveground between shutoff valves. Install in high pressure drip irrigation zones.
- G. Throttling Valves: Install in underground piping in boxes for automatic control valves.
- H. Drain Valves: Install in underground piping in boxes for automatic control valves.

3.7 VALVE BOXES

- A. Provide extensions to valve boxes as required for bury. Place 4" of gravel in bottom of box below valve.

3.8 DRIP IRRIGATION INSTALLATION

- A. Install drip-irrigation piping (drip line) at a depth of 8 inches (8") below the ground surface approximately following the ground contours.
- B. Install dripline with vibratory plow or equivalent with minimal disturbance to soil and vegetation.
- C. Spacing of drip line to be as shown on the approved drawings.
- D. Emitter shall face down in the trench.
- E. Connect drip line to manifold per manufacturer's instructions.
- F. Drip line shall be flushed back to the recirculation tank at a programmable interval to be determined by the EDGE.
- G. Install drip line with vibratory plow or equivalent with minimal disturbance to soil and vegetation.

3.9 AUTOMATIC DRIP IRRIGATION-CONTROL SYSTEM INSTALLATION

- A. Equipment Mounting: Install interior controllers on wall of Control Building.
 - 1. Place and secure anchorage devices. Use setting drawings, templates, diagrams, instructions, and directions furnished with items to be embedded.

2. Install anchor bolts to elevations required for proper attachment to supported equipment.
- B. Install control cable in same trench as irrigation piping and at least 2 inches below or beside piping. Provide conductors of size not smaller than recommended by controller manufacturer. Install cable in separate sleeve under paved areas.

3.10 CONNECTIONS

- A. Install piping adjacent to equipment, valves, and devices to allow service and maintenance.
- B. Connect wiring between controllers and automatic control valves.
- C. Splices: Splices in wiring to the drip field solenoid valves shall be made in a box with direct bury wire nut and strain relief gel-filled connector equal to DryConn by King Innovation.
- D. Where pull and/or splice boxes are needed every 500 feet along collection system to a remote drip field, use Old Castle Box with same material lid as box (not ductile iron) that can be bolted down.

3.11 IDENTIFICATION

- A. Identify system components.
- B. Equipment Nameplates and Signs: Install engraved plastic-laminate equipment nameplates and signs on each automatic controller.
 1. Text: In addition to identifying unit, distinguish between multiple units, inform operator of operational requirements, indicate safety and emergency precautions, and warn of hazards and improper operations.
- C. Warning Tapes: Arrange for installation of continuous, underground, detectable warning tapes over underground piping during backfilling of trenches. See Section 31 20 00 Earth Moving for warning tapes.
- D. Locator Wire: All pressure sewer lines leading to and returning from the drip fields shall have a #12 AWG solid copper clad over steel, high-strength, continuous toning wire with 30 mil HDPE purple coating suitable for direct bury and installed at such a depth that it is detectable with the EDGE'S equipment. Wire shall be taped to the pipe as it is installed.
- E. Mark location of solenoid valves, air release valves, and blow-offs in the drip field using a UV resistant purple plastic post labeled with drip field number and set in concrete. Posts to be furnished by the EDGE.

3.12 FIELD QUALITY CONTROL

- A. Perform tests and inspections.
 - 1. Manufacturer's Field Service: Engage a factory-authorized service representative to inspect components, assemblies, and equipment installations, including connections, and to assist in testing.
- B. Tests and Inspections:
 - 1. Leak Test: After installation, charge system and test for leaks. Repair leaks and retest until no leaks exist.
 - 2. Operational Test: After electrical circuitry has been energized, operate controllers and automatic control valves to confirm proper system operation.
 - 3. Test and adjust controls and safeties. Replace damaged and malfunctioning controls and equipment.
- C. Any irrigation product will be considered defective if it does not pass tests and inspections.
- D. Prepare test and inspection reports.

3.13 STARTUP SERVICE

- A. The Contractor/Installer shall perform a startup service for EDGE for all equipment.
 - 1. Complete installation and startup checks according to manufacturer's written instructions.
 - 2. Verify that controllers are installed and connected according to the Contract Documents.
 - 3. Verify that electrical wiring installation complies with manufacturer's submittal.

3.14 ADJUSTING

- A. Adjust settings of controllers.
- B. Adjust automatic control valves to provide flow rate at rated operating pressure required for each sprinkler circuit.

3.15 CLEANING

- A. Flush dirt and debris from piping and other devices.

3.16 DEMONSTRATION

- A. The Contractor/Installer shall perform a demonstration for EDGE for all equipment.

3.17 PIPING SCHEDULE

- A. Install components having pressure rating equal to or greater than system operating pressure.

EFFLUENT DRIP DISPERSAL

- B. Piping in control-valve boxes may be joined with flanges or unions.
- C. Underground irrigation supply and return forcemain piping, NPS 4 and smaller, shall be the following:
 - 1. SDR 17, PVC, pressure-rated pipe; Schedule 80, PVC socket fittings; and solvent-cemented joints.
- D. Supply and return manifolds shall be, NPS 2 and smaller, shall be the following:
 - 1. Schedule 40, PVC pipe and socket fittings; and solvent-cemented joints.

3.18 VALVE SCHEDULE

- A. Underground, Shutoff-Duty Valves: Use the following:
 - 1. NPS 2 and Smaller: Curb valve, curb-valve casing, and shutoff rod.
 - 2. NPS 3 and Larger: Iron gate valve, resilient seated; iron gate valve casing; and operating wrench(es).

3.19 FLUSHING

- A. Drip line shall be flushed back to the recirculation tank at a programmable interval to be determined by the EDGE.

END OF SECTION 32 84 00

PART 1 – GENERAL

1.1 SCOPE

- A. The work of this section includes furnishing all labor, materials, tools, and equipment necessary to furnish and install a fixed film aerobic process type treatment system with all necessary equipment and appurtenances for efficient operation as specified herein and as shown on the drawings.

1.2 DESIGN CRITERIA

- A. The materials and equipment covered by this specification are intended to be standard materials and equipment of proven ability as manufactured by reputable concerns. Equipment shall be designed and constructed in accordance with the best practice of the industry and shall be installed in accordance with the manufacturer's recommendations and the Contract Documents.
- B. The system shall be designed to operate under the design criteria detailed in SECTION 2.1(A).

1.3 PRODUCT HANDLING

- A. All materials and equipment shall be shipped, stored, handled, and installed in such a manner as not to degrade quality, serviceability, or appearance. The unit(s) shall be stored outdoors in a secured location according to the manufacturer's recommendations. Loose-shipped items shall be stored in a clean, dry location free from precipitation and excess moisture.

1.4 SUBMITTALS

- A. Three complete sets of shop drawings and/or site-specific Technical Manuals shall be submitted for all items to be furnished. Submittals shall include all equipment and components, catalogue cuts, wiring diagrams, control schematics, and all pertinent installation, operation, and maintenance procedures to maintain efficient operation.

PART 2 – MATERIALS

2.1 TREATMENT SYSTEM

- A. General
 - 1. Treatment system shall be as required to meet the project requirements.
 - 2. The treatment system shall include a trickling filter situated over a final settling tank. The treatment system shall be delivered complete from the supplier and shall

RECIRCULATING MEDIA FILTERS

include: random packed PVC manufactured media, ventilation fan, dosing pump(s), sludge return pump, internal piping, wiring, and controls for a complete operational treatment system.

3. The trickling filter portion of the tank shall have fiberglass inner and outer skins with the cavity between filled with polyvinyl chloride foam insulation. The remainder of the unit shall be constructed of FRP or plastic as recommended by the equipment manufacturer.
4. All internal piping shall be Schedule 40 PVC plastic pipe.
5. The unit shall withstand normal pressures from the interior hydrostatic load and from the soil.
6. Flange factory sealed for water tightness.
7. The effluent design criteria are as follows:

Flow	= 300 gpd/lot
BOD5	≤ 45 mg/L
TSS	≤ 40 mg/L
TKN	= 50 mg/l
Total Nitrogen	≤ 10-15 mg/L
Escherichia coli	= 94 colonies / 100 µL

B Pre-Cast Mounting Pad

1. The Contractor shall be responsible for providing a precast mounting pad upon which to set each treatment vessel. The mounting pad shall be as shown on the drawings.

C. Filter Media

1. The PVC randomly packed filter media with void ratio >95%, shall be UV resistant, resistant to a wide range of aqueous solutions, acids, alkalis, oxidizing agents, oils, fats, and alcohols.

D. Settling Tank

1. The settling tank shall be cone shaped and have 60-degree sloped sides to prevent the accumulation of biological and inorganic suspended solids and shall contain the necessary internal baffling to prohibit short-circuiting of the wastewater.

E. Ventilation Fan

1. CSA and UL approved 115v/1ph/60hz, ball bearing fan.
2. Minimum airflow rate shall be 58 cfm to 240 cfm.
3. Housing & blade detail: aluminum housing & polycarbonate blade.

F. Pumps: The CSA and UL approved dosing pumps and recycle pumps shall be stainless steel submersible pumps. All pumps

RECIRCULATING MEDIA FILTERS

shall have an internal high temperature shut off switch. Each pump shall be rated for intermittent or continuous duty when fully submerged between 0°C-55°C. The alternating dosing pumps shall be controlled such that when one pump fails, the remaining pump will complete both dosing cycles. A dry contact shall be installed in each control panel so that a common alarm may be wired to a convenient location.

G. Float Switches

1. CSA & UL approved low level, 115v/1ph/60hz, mechanically activated wide-angle switch. Float switch shall be installed to prevent the recycle pump from operating when water levels are abnormally low.

H. Power Supply

1. Dedicated power per unit for each shall be 20 to 40 amp and 115v/1 ph/60 hZ to 208-230v/1ph/60 hZ.

I. Control Panel

1. The UL approved control panel shall be furnished with an audio and visual alarm for pump failure & tripped circuit breaker conditions, an exterior alarm silence button, and an on/off/test power/alarm toggle switch.
2. Within the NEMA 4X enclosed fiberglass panel pump, the following shall be provided: timers, relays, terminal strip, on/off/test switches, run lights, dosing pump alternator, circuit breakers, and current sensors.
3. Contact type: dry contact shall be installed in each control panel so that a common alarm may be wired to a convenient location.
4. The alarm shall sound and the light shall flash continuously until the alarm is reset on shut off.

J. Wiring

1. The electrical contractor shall complete the wiring between the control panel and the terminal strip, with the fan module meeting all local, state, and federal codes.
2. All fittings, connections, etc... shall be of weatherproof and watertight construction. Ground terminals are provided in both the main panel and the junction box for each unit. Each ground terminal shall be wired to an earth ground.
3. Care shall be taken to match the wires between the control panel and the terminal strip within the fan module located on each unit.

K. Warranty

RECIRCULATING MEDIA FILTERS

1. All equipment shall be warranted against defects in materials and workmanship for a period of one year from installation date.
- L. Spare Parts
1. A recommended list of spare parts shall be detailed in the site-specific Technical Manual that details the Installation, Operation & Maintenance procedures.
- M. Services Provided
1. An approved manufacturer's representative shall provide the following services for each project:
 - a. The general contractor shall install the unit(s) and all related components.
 - b. Provide onsite technical assistance for the handling and positioning of the unit(s) the day of installation.
 - c. Return to the site for testing and/or commissioning of the unit(s) upon substantial completion of site work by the general contractor (backfill, piping, electrical, grading, etc.).
 - d. The manufacturer shall install the randomly packed PVC media and pumps into the treatment unit(s).
 - e. The manufacturer shall be available to train the operator(s) and instruct the OWNER on the operation the day of testing/commissioning.
 - f. Remain accessible to the CITY and/or operator for phone consultation.
 - g. Be available on a contract basis for additional site visits or consultation.

PART 3 – EXECUTION

3.1 INSTALLATION

- A. All materials and equipment shall be installed in a neat, workmanlike manner.
- B. Installation of the treatment system and ancillary equipment supplied by the manufacturer shall be in accordance with written instructions provided by the manufacturer or approved representative.
- C. All applicable treatment units supplied by the manufacturer shall be installed with sufficient ballast to offset buoyant forces due to induced or high groundwater conditions.

3.2 CLEAN UP

- A. Prior to start-up and field-testing, all foreign matter shall be removed from the grease trap(s), pump station(s) and treatment unit(s).

3.3 FIELD TESTING

- A. The treatment system shall be field-tested using clean, fresh water prior to acceptance. The system shall be operated to test the efficiency of all components. All systems, controls, and sequences shall be operated and demonstrated as operating as approved. The contractor shall perform all tests and shall be responsible for all necessary temporary connections, testing equipment and utilities and shall provide and dispose (if necessary) of all water used. A factory trained representative shall be present for the testing.

3.4 PROHIBITIONS

- A. Organic solvents, fuel oils, paints and thinners, photographic fluids, floor waxes and strippers, solutions containing copper compounds, cleaning agents containing quaternary ammonium chlorides and products containing compounds that are documented to inhibit biological growth should not be discharged to the sewage treatment system.

END OF SECTION 46 07 53

46 07 54 MOVING BED BIOFILM REACTOR TREATMENT SYSTEMS

PART 1 GENERAL

1.1 SCOPE

- A. The work of this section includes furnishing all labor, materials, tools and equipment necessary to furnish and install a factory built, Moving Bed Biofilm Reactor (MBBR) with all the necessary equipment and appurtenances for efficient operation as specified herein and as shown on the drawings.

1.2 DESIGN CRITERIA

- A. The materials and equipment covered by this specification are intended to be standard materials and equipment of proven ability as manufactured by reputable concerns. Equipment shall be designed and constructed in accordance with the best practice of the industry and shall be installed in accordance with the manufacturer's recommendations and the Contract Documents.
- B. The MBBR reactor shall be designed to operate under the design criteria detailed in SECTION 2.1.

1.3 PRODUCT HANDLING

- A. All materials and equipment shall be shipped, stored, handled and installed in such a manner as not to degrade quality, serviceability or appearance. The MBBR equipment shall be stored indoors/outdoors in a secured location according to the manufacturer's recommendations. If stored outdoors, the bags of polyethylene media must be completely covered to provide UV protection. Loose-shipped items shall be stored in a clean, dry location free from precipitation and excessive moisture.

1.4 SUBMITTALS

- A. The following shall be submitted in accordance with the specifications:
 - 1. Three (3) complete sets of shop drawings and/or site-specific Technical Operation and Maintenance Manuals. The Operation and Maintenance Manual shall contain descriptions of treatment plant and equipment operation; shop drawings, field reports, operation and maintenance procedures, process control guidelines, equipment specifications, schedules, and spare parts information.
 - 2. Drawings showing assembly, accessories, installation details and applicable control panel wiring diagrams.
 - 3. Foundation layouts and templates, where appropriate.
 - 4. A certified motor data sheet for each type and size of motor. The data sheet shall include each motor application, manufacturer, type, frame, size, bearing type, lubrication medium, insulation type and enclosure type.

1.5 PROHIBITIONS

46 07 54 MOVING BED BIOFILM REACTOR TREATMENT SYSTEMS

- A. Organic solvents, fuel oils, paints and thinners, photographic fluids, floor waxes and strippers, solutions containing copper compounds, cleaning agents containing quaternary ammonium chlorides and products containing compounds that are documented to inhibit biological growth shall not be discharged to the sewage treatment system.

PART 2 MATERIALS AND PRODUCTS

2.1 MBBR

A. MBBR (Aerobic)

1. The MBBR aeration reactor(s) shall be constructed of cast in place concrete; pre-cast concrete, fiberglass reinforced plastic tank(s), 304 stainless steel or epoxy coated carbon steel tank(s) with welds of adequate cross section for the joint involved. Tank walls and bottoms shall be reinforced as required to withstand all hydrostatic pressures exerted by the interior hydrostatic load and the soil. Above ground reactor(s) may be encased in foam insulation depending on seasonal wastewater temperatures and permit discharge requirements. Each aeration compartment shall incorporate UV protected dynamic polyethylene media that is 100% submerged, to provide completely mixed fixed film treatment. The treatment system shall maintain high biomass populations and long sludge ages to minimize solids generation and the solids loading to the secondary clarifier(s). The aerobic moving bed biofilm reactor internals shall include an PVC or stainless steel aeration grid and stainless-steel media retention screen. The treatment plant maximum design criteria are:
2. The effluent design criteria are as follows:

Required Effluent

Flow, gpd	= 300
BOD ₅ , mg/l	= (per 2.1.A.2) ≤ 45 mg/L
TSS, mg/l	= (per 2.1.A.2) ≤ 40 mg/L
TKN, mg/l	= 50 mg/l
Total Nitrogen,mg/l=	≤ 10-15 mg/L
Escherichia coli	= 94 colonies / 100 μL

B. Aeration/Mixing System for Aerobic Zones:

Each aeration reactor shall incorporate a mechanical system to mix the wastewater and media, MLSS (if applicable) and transfer oxygen to the biomass. The aerobic zones shall be completely mixed and designed to supply optimum and efficient aeration and contact for continual

exposure of the waste being treated by the biofilm attached to the media. The mechanical aeration equipment shall be properly sized to provide even growth conditions throughout the media and eliminate dead spots within the aeration tank. The mechanical aeration equipment shall consist of rotary dual or tri-lobe positive displacement blower(s) and a coarse or fine bubble air diffuser assembly. The following equipment is an acceptable means of providing aeration and mixing in the reactor(s).

1. Rotary dual or tri-lobe positive displacement blower(s). The motors shall be EPA Act compliant, TEFC or ODP enclosed with a 1.15 service factor. Blower motors shall be rated for (230V or 460V/3Ph/60Hz). The air inlet(s) shall have a built-in silencer, and the assembly shall be equipped with an air release valve, check valve and pressure gauge. Optional temperature and air filter monitoring can be included. Blower assemblies shall be mounted on a painted steel base, fiberglass base with hood or in a steel sound attenuated enclosure.
2. 304 stainless steel or schedule 80 CPVC/PVC coarse bubble diffuser assemblies shall be installed on the floor of each aeration compartment to evenly distribute air and completely mix the tank's contents. Each aeration grid assembly shall include a drop leg, manifold with throttling valve(s), fixed headers and coarse or fine bubble diffusers.

C. Filter Media

1. The neutrally buoyant dynamic HDPE biofilm carrier media within the bioreactor shall provide a protected surface for the growth of a diverse biofilm community. The media shall have a protected surface-to-volume ratio of $500 \text{ m}^2/\text{m}^3$ that shall allow for a high concentration of microorganisms to thrive within the internally protected areas and significant void space to eliminate plugging and allow for transfer of oxygen and nutrients to the biofilm. The approximate dimensions of each media element are 25.4 mm in diameter and 12.7 mm long (approximately 1" x 1/2"). The media shall be resistant to ultraviolet radiation and a wide range of aqueous solutions, acids, alkalis, oxidizing agents, oils, fats and alcohols.

D. Media Retention Screens

1. Each treatment compartment containing the filter media shall include an appropriately sized 304 stainless steel wedge wire media retention screen(s). The purpose of the screen(s) is to retain the HDPE filter media in the basin. The screens shall have an open area >75% and shall provide adequate flow through capacity. The screens clear space openings shall not be greater than 3/8" (10 mm).

E. Treatment Reactor Foundation

1. If required, the contractor shall be responsible for providing a concrete foundation on which the treatment reactor(s) shall be set. The foundation(s) shall be designed and constructed in accordance with the engineering site plans, and applicable Federal and State building codes. The foundation design must consider the buoyant forces due to the expected high groundwater conditions and the equipment anchoring requirements.
- F. Secondary Clarification
1. The following shall be acceptable means of secondary solids removal.
 - a. Fiberglass, steel or concrete hopper bottom clarifier(s) or standard rectangular and circular mechanical clarifier(s). The clarifier(s) shall contain a scum removal mechanism, a sludge pumping system, a scum baffle and an overflow weir. The secondary sludge removal pump(s) shall be rotary lobe, submersible sewage, or airlift type. The CSA and UL approved sludge removal pump(s) shall be 115V, or (230V/1Phase or 230V-460V/3Phase/60Hz).
 - b. High-rate trickling filter with integral secondary clarifier unit.
 - c. Dissolved Air Floatation (DAF) unit.
- G. Power Supply
1. Each supplied NEMA rated control panel shall have dedicated power feeds that shall be sized and installed according to the National Electrical Code, Local Electrical Codes and all applicable Codes.
 2. Incoming voltage imbalances greater than 2% are capable of causing large unequal currents in the variable frequency drive(s) (VFD's). An input line reactor is recommended when line voltage imbalances are greater than 2%.
 3. Voltages for equipment shall be consistently within 10% of the motor name plate.
- H. Control Panels
1. The control panels and enclosures shall, at a minimum, be designed to conform to the applicable regulations, standards, specifications and codes in effect on the date the detailed design and drawings are accepted. The enclosures shall be of the NEMA type, provided with locking doors and appropriate to protect the control panel components from the environmental factors present in the location where they are to be installed.
 2. The control panel(s) and enclosure(s) shall be capable of operating successfully in the environments in which they are to

- be installed. The control panels and enclosures shall be protected against all reasonably foreseen environmental factors.
3. The environmental factors to be considered in the control panel and enclosure design include, but are not limited to:
 - a. Direct sunlight: Whenever possible the enclosure shall not be installed in direct sunlight. When installation in direct sunlight is unavoidable a sunshield(s) shall be provided by the general contractor or the enclosure(s) shall be fitted with an air venting or air conditioning system(s).
 - b. High humidity and temperature: Enclosures for use in high humidity or high temperature conditions shall be air-conditioned. Condensation from the air conditioner must drain outside the enclosure. Air conditioner(s) shall be thermostatically controlled.
 - c. Extreme cold: Enclosures for use in locations that experience extreme cold shall be installed in a heated control building.
 - d. Explosive hazardous environment: Installations in explosive environments are recommended or anticipated. The manufacturer must be notified if enclosures and equipment are required to be explosion proof or intrinsically safe.
 4. Each analog and/or PLC based, NEMA rated enclosed control panel shall be furnished with an audio and visual alarm to alert the operator of motor failure, motor overload, and/or abnormally low or high wastewater levels.
 5. The control panel(s) shall include programmable logic controllers with an appropriate operator interface terminal (if applicable), terminal strips, run lights (if applicable), alternators, motor contactors, overload relays and current sensors. A dry contact shall be provided so that a common alarm may be wired to a convenient location. If specified, an auto dialer shall be provided to remotely alert the owner/operator of an alarm condition associated with the supplied equipment.
 6. Optionally, the control system may be upgraded to include an internet based remote telemetry monitoring and reporting system.
- I. Warranty
1. The supplied equipment shall be free from defective materials and workmanship for a period of (12) months from the date of commissioning or (18) months from delivery of equipment to the site, whichever comes first. The manufacturer shall furnish

46 07 54 MOVING BED BIOFILM REACTOR TREATMENT SYSTEMS

replacement parts for any components considered in the opinion of the manufacturer to be defective during the guarantee period.

J. Spare Parts

1. A recommended list of spare parts shall be contained in the site specific Operation & Maintenance Manual.

K. Services Provided

1. An approved manufacturer's representative shall provide the following services for each treatment plant installation. The general contractor shall install the unit(s) and all related treatment system components.
 - a) Be available to the contractor to review the shop drawing submittals.
 - b) Provide onsite technical assistance for the handling and positioning of the supplied treatment components the day of installation.
 - c) Return to the site for testing and/or commissioning of the supplied components(s) upon substantial completion of site work by the general contractor (backfill, interconnecting piping, electrical, grading, etc.). The manufacturers' representative shall be available to train the operator(s) and instruct the owner on proper operation of the treatment system the day of testing/commissioning.
 - d) Remain accessible to the owner and/or operator for phone consultation.
 - e) Be available on a contract basis for additional site visits or consultation.

PART 3 EXECUTION

3.1 INSTALLATION

- A. All materials and equipment shall be installed in a neat, workmanlike manner by the general contractor.
- B. Installation of the treatment system and ancillary equipment supplied shall be in accordance with written instructions provided by the manufacturer.
- C. The reactor(s) and all applicable treatment units supplied shall be installed with sufficient ballast to offset buoyant forces due to induced or high groundwater conditions. Alternatively, the site shall be equipped with provisions to reduce the groundwater table around the reactors to be emptied.

3.2 CLEAN UP

46 07 54 MOVING BED BIOFILM REACTOR TREATMENT SYSTEMS

- A. Prior to start-up and field-testing, all foreign matter shall be removed from all tanks including but not limited to; primary tank(s), mechanical bar screen(s), grit chamber(s), pump station(s) and treatment unit(s), secondary clarifier(s), sludge holding tank(s), etc.

3.3 FIELD TESTING

1. The treatment system and all ancillary treatment equipment shall be field-tested using clean fresh water prior to acceptance. All electrical motors and field wire connections shall be free from faults prior to equipment testing and all motor rotation shall be verified. The system shall be operated to test the efficiency of all components. All systems, controls, and sequences shall be operated and demonstrated as operating as designed and approved. The contractor shall perform all tests and shall be responsible for all necessary temporary connections, testing equipment and utilities and shall provide and dispose (if necessary) of all water used. A factory-trained representative shall be present for the testing.

END OF SECTION 46 07 54

APPENDIX

STANDARD DETAILS

for

DECENTRALIZED WASTEWATER SYSTEMS

INDEX

DRAWING TITLE

Typical Collection Main Testing port

Utility Line Separation Crossing

Silt Fence

Typical Service Connection (Pressure)

Typical Stub for Extension

Wastewater Treatment Stone Access Drive

Typical Residential Service Connection Plan

Drip Field Effluent Disposal – Schematic

Trench Detail – Drip Zone Supply & Return Piping

Drip Emitter Piping

Drip Piping Manifold Tap

Drip Disposal Piping End Manifold Elevation

Return Line Air Release And Check Valve Assembly

End of Supply Line Drip Disposal Air Release Valve And Blow-Off
Assembly

Electric Solenoid Valve

Erosion / Siltation Barrier

Collection Piping Trench Details

Collection Piping Joint Trench Details

1,500 Gallon STEP Tank

Residential Control Panel

Air Release Valve Assembly

Line Valve – Outside Pavement

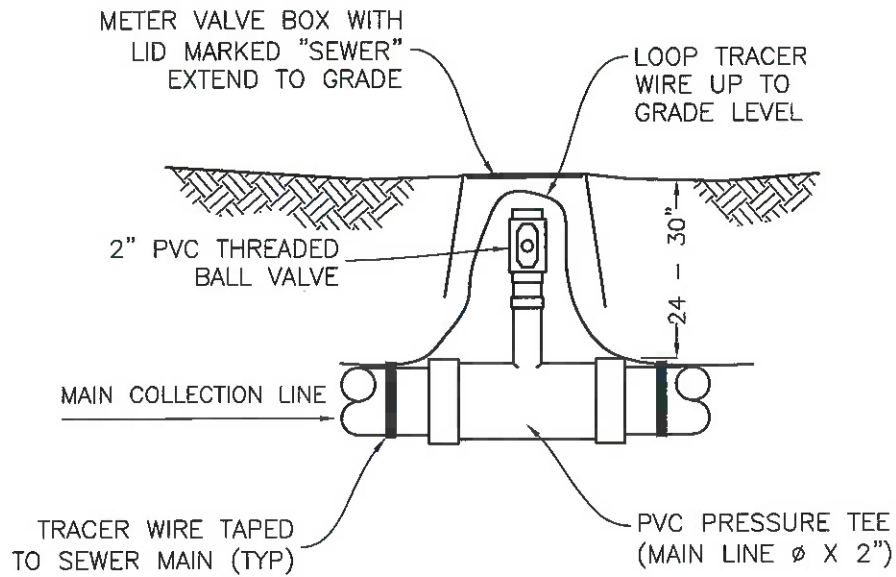

INSTALL ONE (1) TESTING PORT PER COLLECTION LINE. COORDINATE INSTALLATION/LOCATION WITH UTILITY INSPECTOR, OR ADENUS ENGINEER. LOCATION OF TESTING PORT TO BE NOTED ON AS-BUILT DRAWINGS.

TYPICAL COLLECTION MAIN TESTING PORT

Collection Line Testing Port

REVISION:

DATE: 11-1-2025

SCALE: NTS

FILENAME: 25102-Details

PREPARED BY:



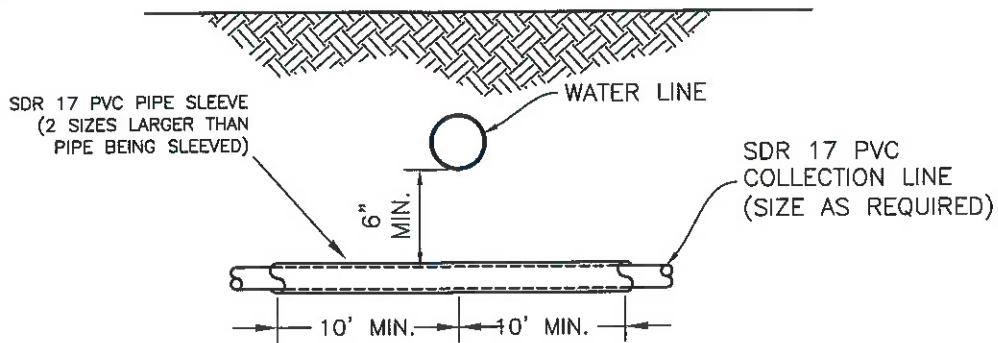

** ONLY 6" (MIN.) OF SEPARATION MUST BE MAINTAINED IF SEWER LINE IS SLEEVED 10' (MIN.) BEYOND BOTH SIDES OF CROSSING WITH WATER LINE. OTHERWISE, 18" (MIN.) OF SEPARATION MUST BE MAINTAINED.

TYPICAL SEWER - WATER LINE CROSSING (WITH SLEEVE)

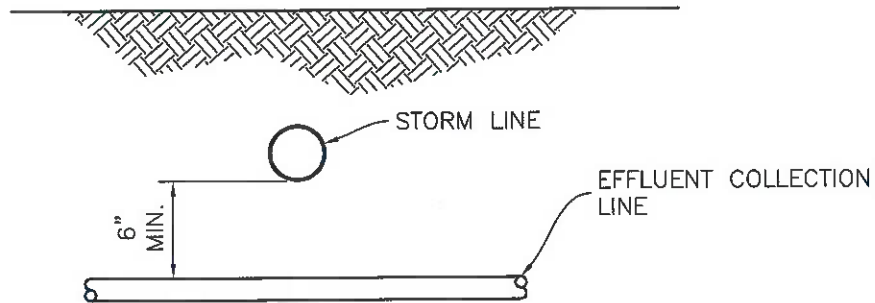

ALL FITTINGS AND VALVES TO BE SCH40 PVC GLUE JOINT PRESSURE RATED

TYPICAL SEWER - STORM LINE CROSSING

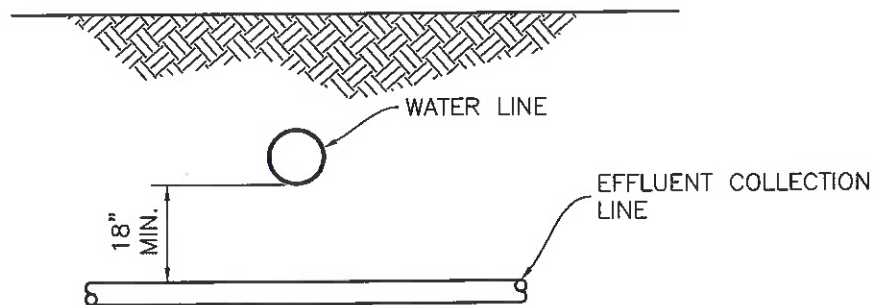

TYPICAL SEWER - WATER LINE CROSSING

Utility Line Separation Crossing

REVISION:

DATE: 11-1-2025

SCALE: NTS

FILENAME: 25102-Details

PREPARED BY:



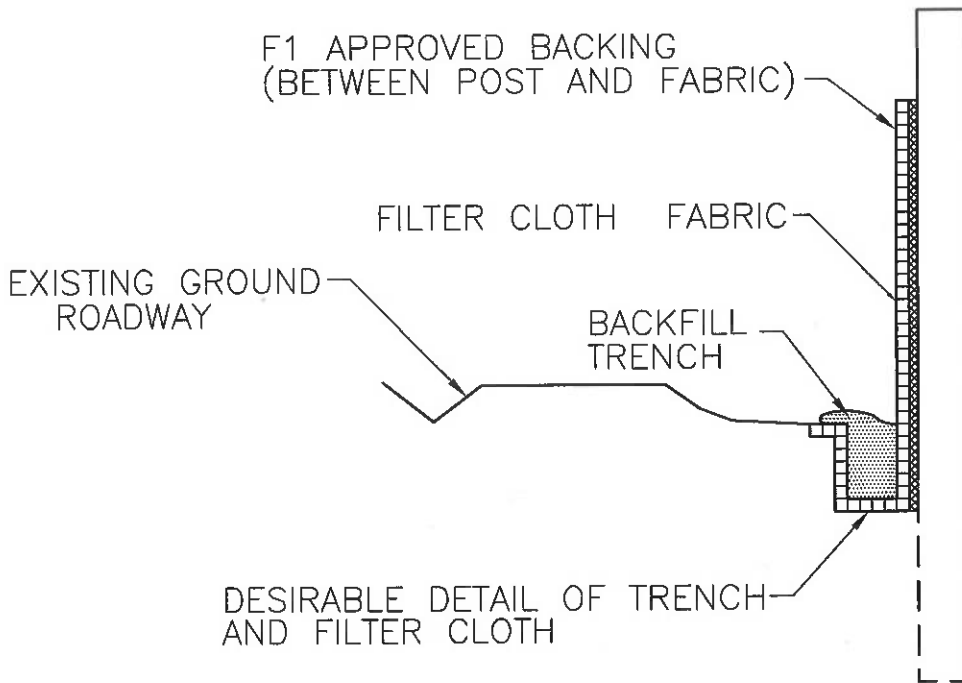
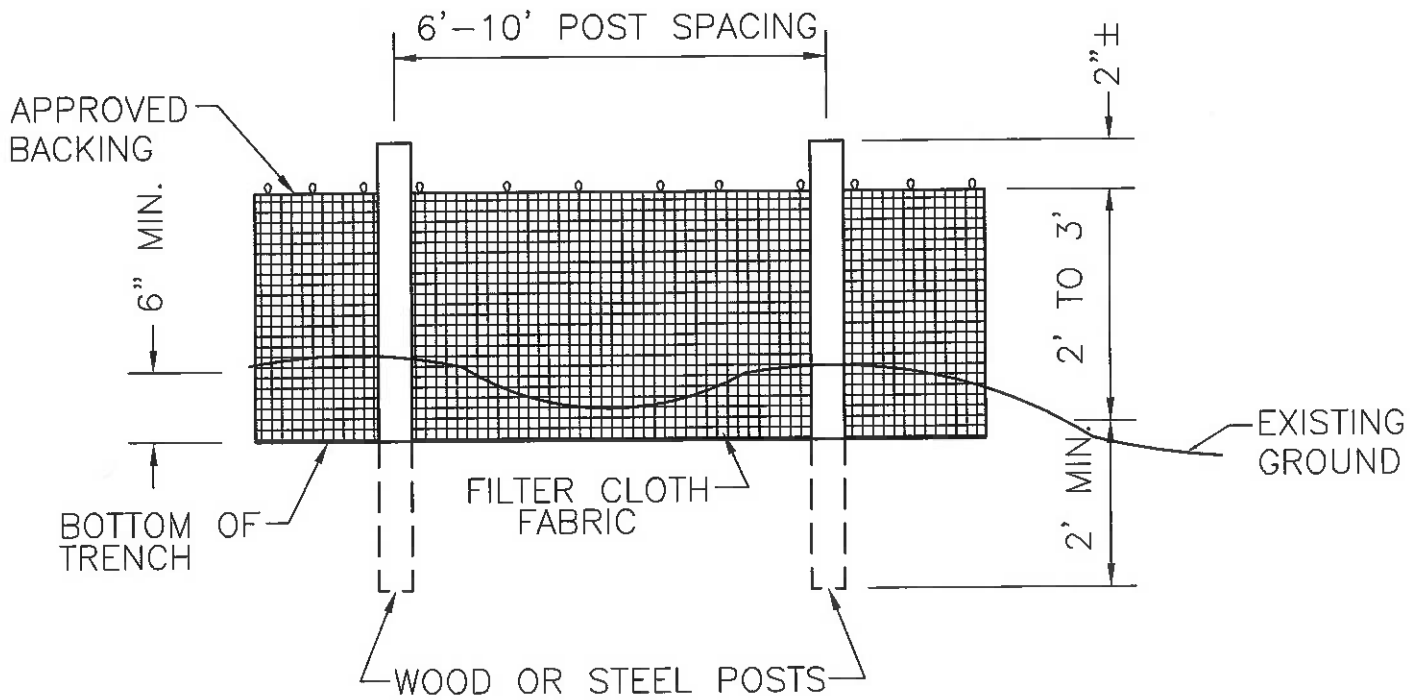

SILT FENCE DETAIL

SCALE ————— NONE

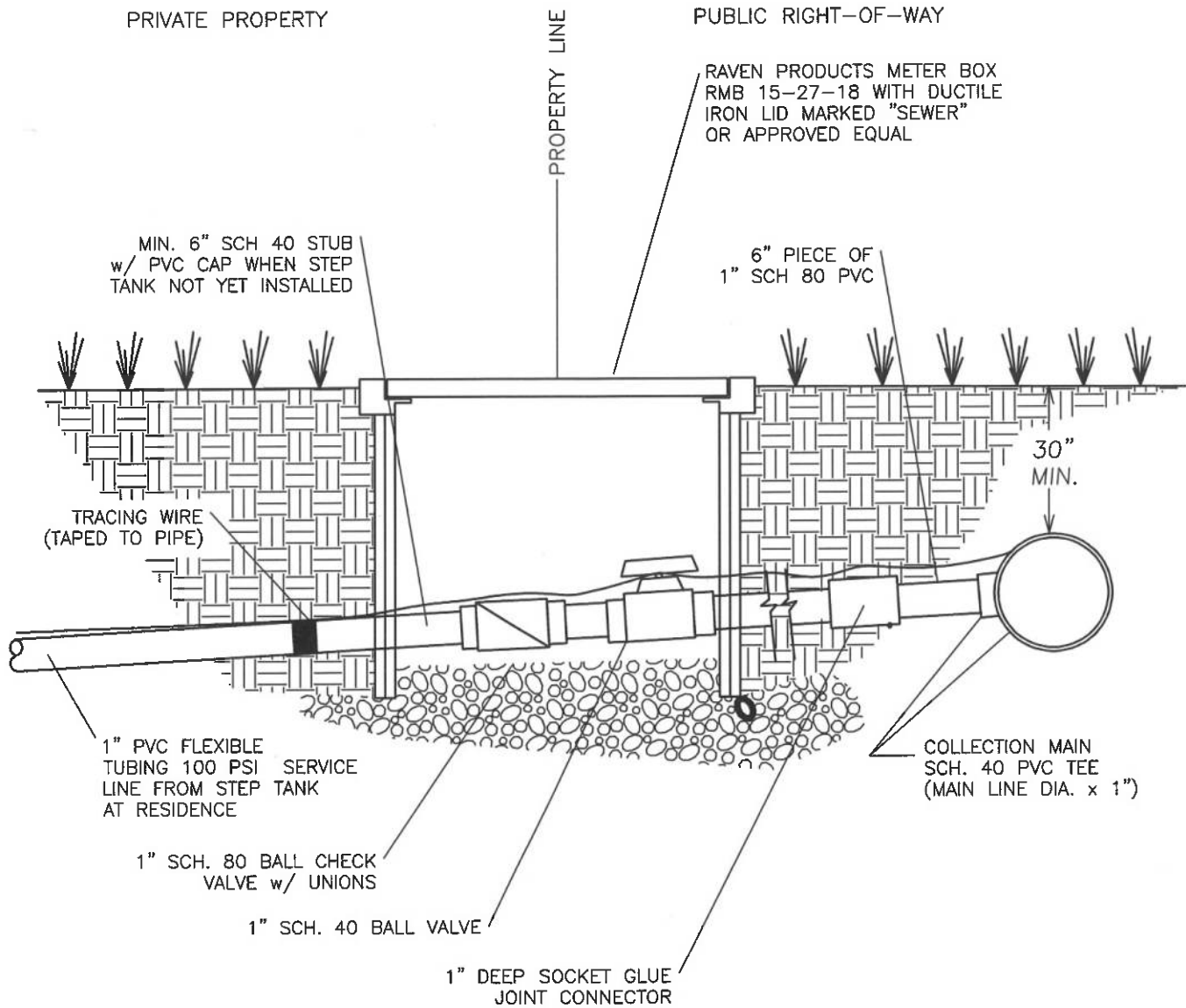

NOTE:
SERVICE CONNECTION METER BOX TO BE A MAXIMUM
2 FT. FROM PROPERTY LINE ON PRIVATE PROPERTY

TYPICAL SERVICE CONNECTION (PRESSURE)

SCALE _____ NONE

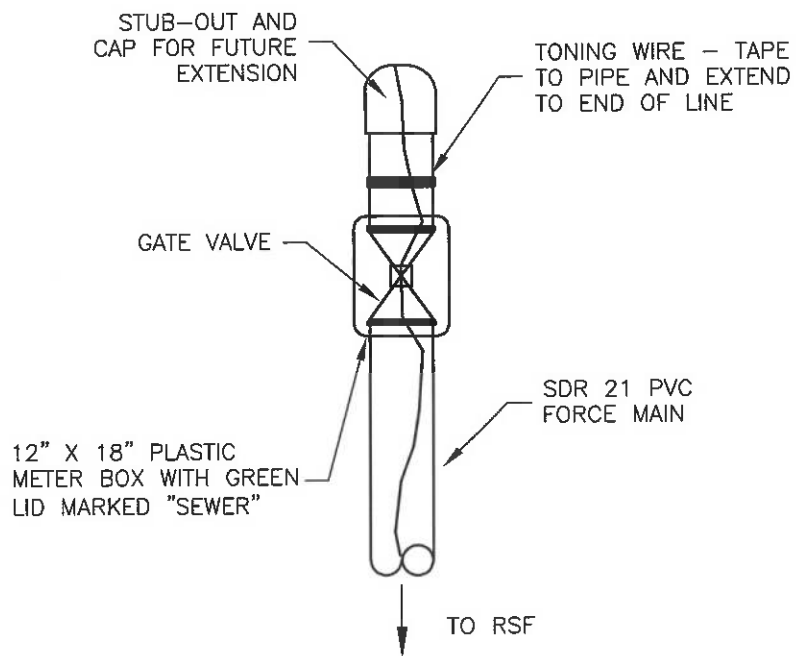

TYPICAL STUB FOR EXTENSION

N.T.S.

**** GATE VALVE / BALL VALVE NOTE**

ON COLLECTION LINES 4"Ø, AND SMALLER, SCH40 PVC BALL VALVES WILL BE USED.

ON COLLECTION LINES 6"Ø, AND LARGER, FLOWMASTER MECHANICAL JOINT SQUARE HEAD VALVES, OR EQUAL WILL BE USED.

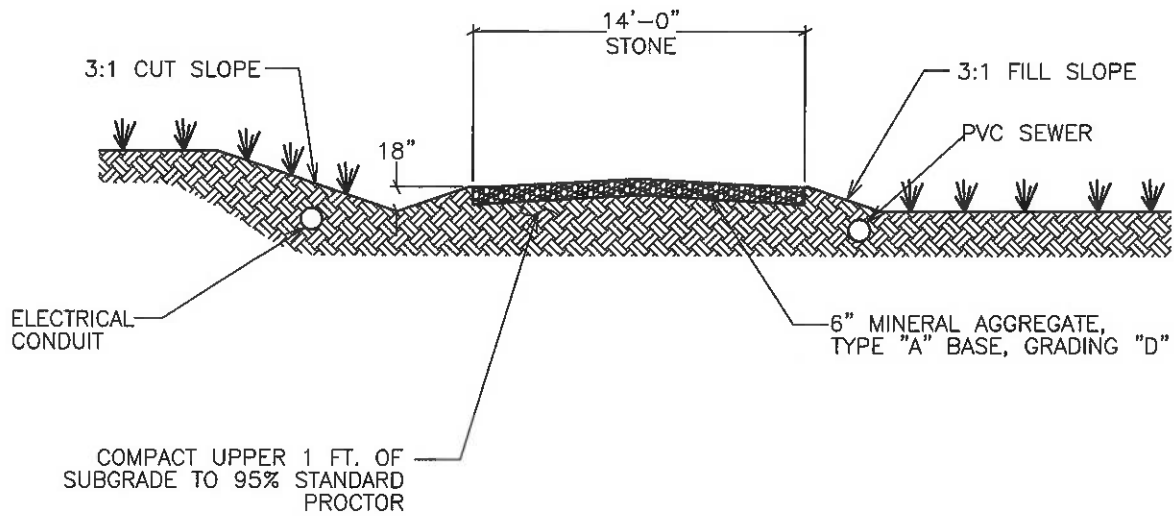

NOTE:
 ACCESS DRIVE MATERIALS AND CONSTRUCTION
 PER STANDARD SPECIFICATIONS OF THE TENNESSEE
 DEPARTMENT OF TRANSPORTATION, LATEST EDITION

WASTEWATER TREATMENT STONE ACCESS DRIVE

SCALE _____ NONE

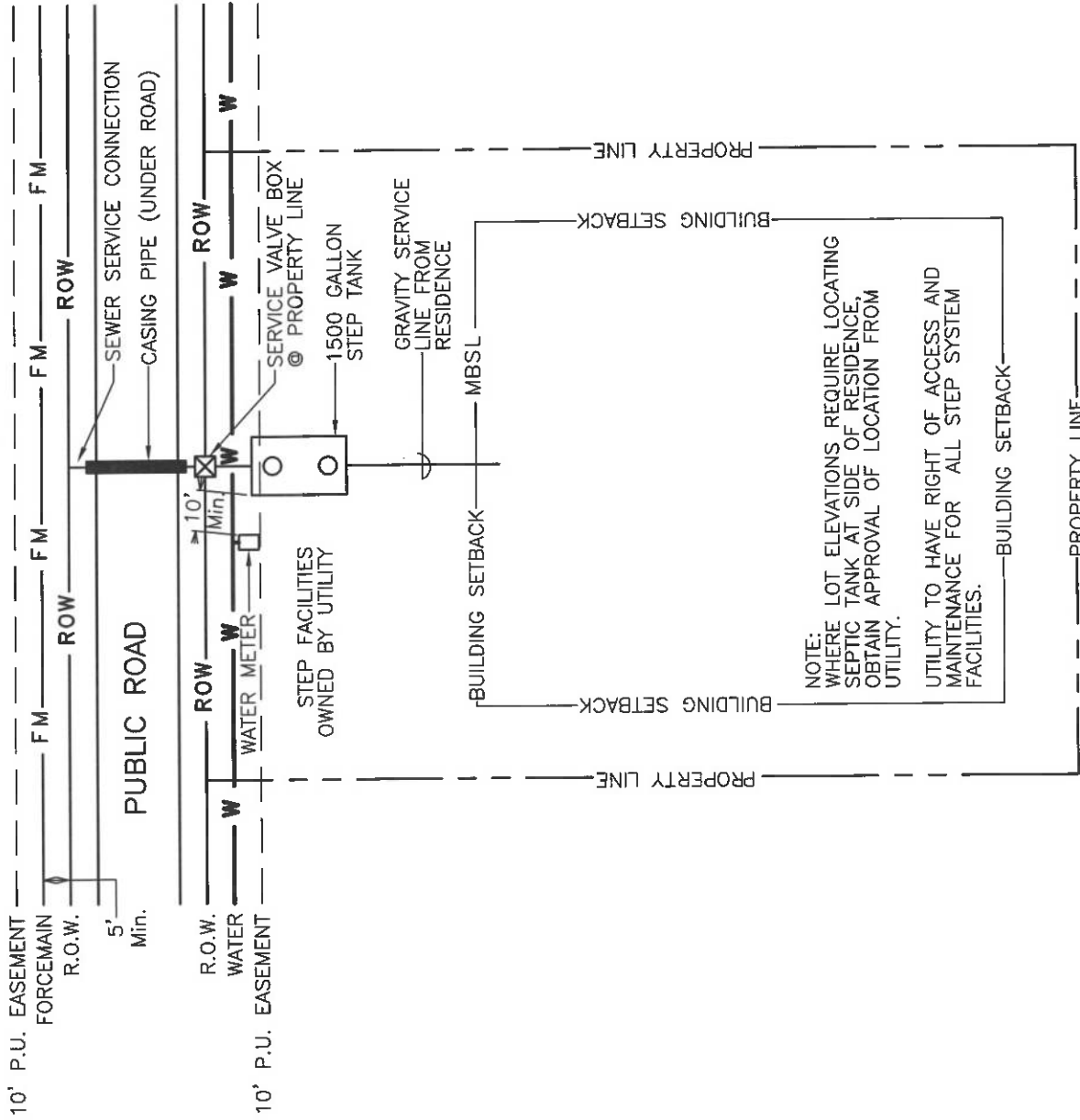

TYPICAL RESIDENTIAL SERVICE CONNECTION PLAN

SCALE NONE

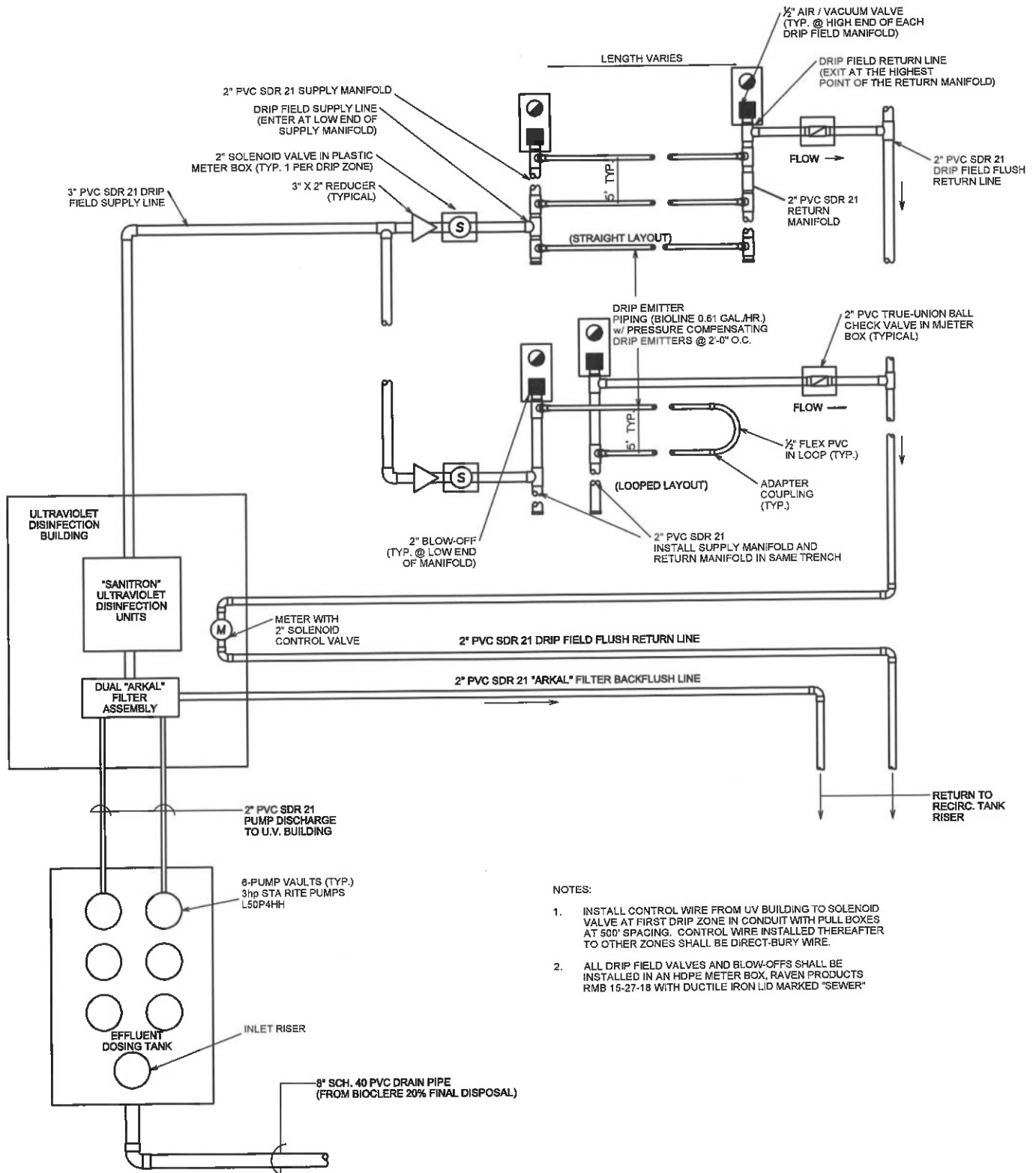

DRIP FIELD EFFLUENT DISPOSAL - SCHEMATIC

NOT TO SCALE

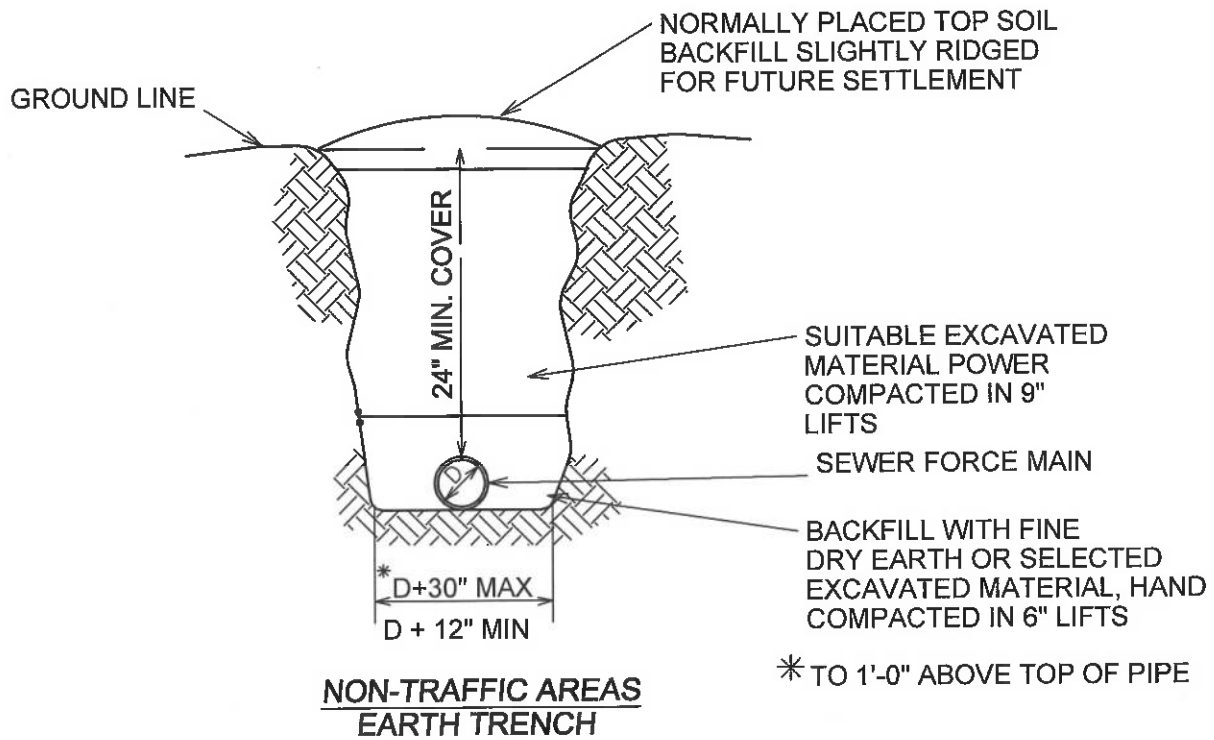

TRENCH DETAIL - DRIP ZONE SUPPLY & RETURN PIPING

NOT TO SCALE

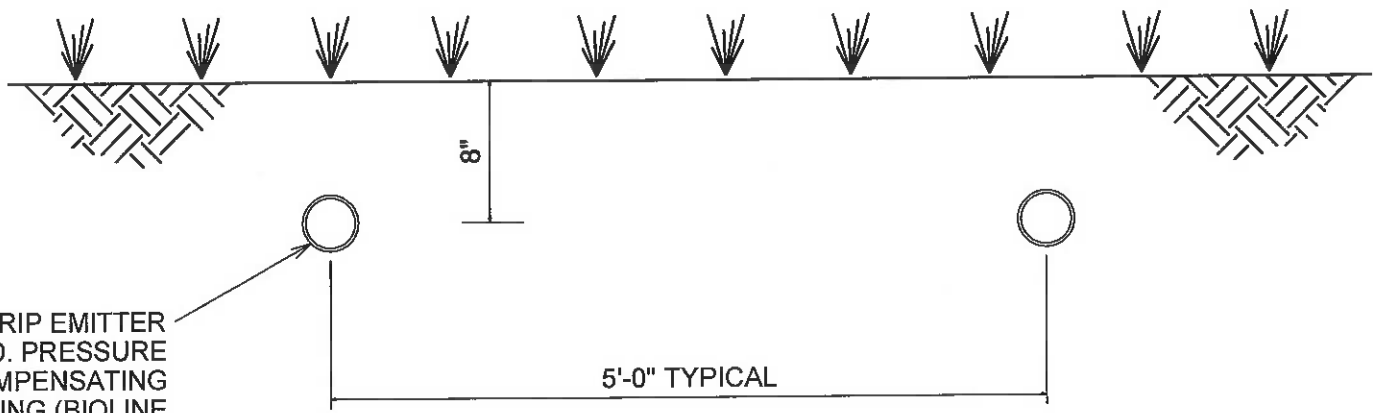

DRIP EMITTER
0.57" I.D. PRESSURE
COMPENSATING
TUBING (BIOLINE
0.61 GAL. / HR.)

NOTE:
DRIP EMITTER PIPING SHALL BE PLOWED IN PLACE

DRIP EMITTER PIPING

NOT TO SCALE

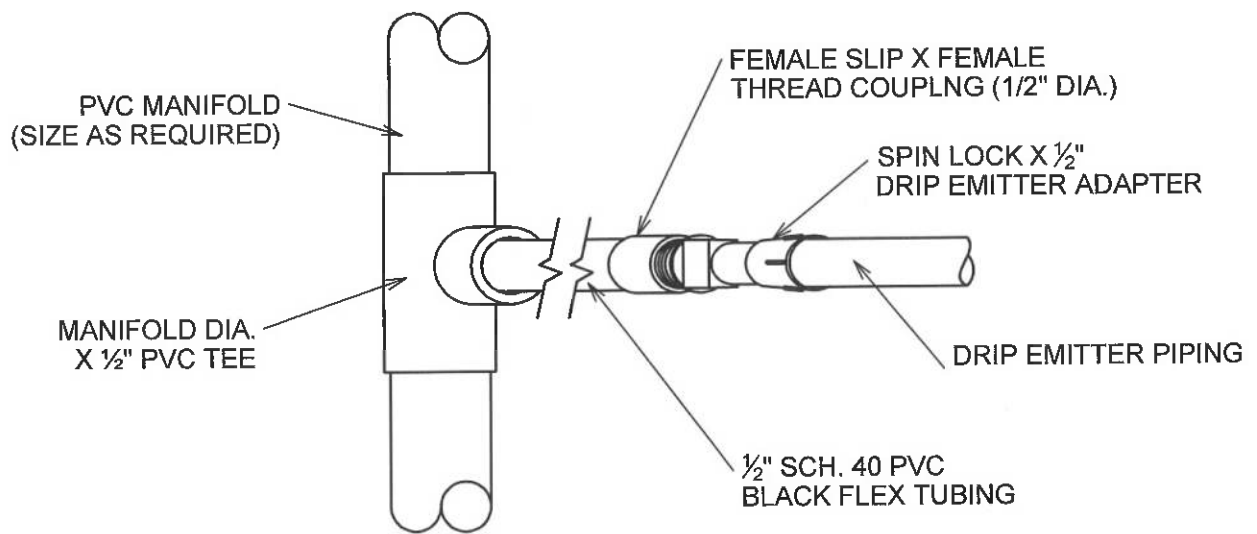

DRIP PIPING MANIFOLD TAP

NOT TO SCALE

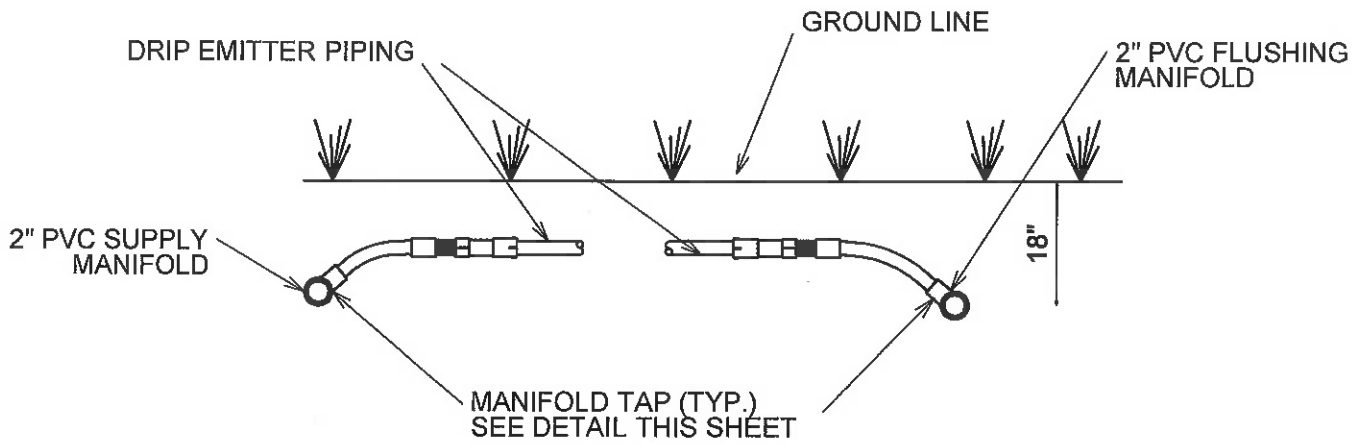

DRIP DISPOSAL PIPING
END MANIFOLD ELEVATION

NOT TO SCALE

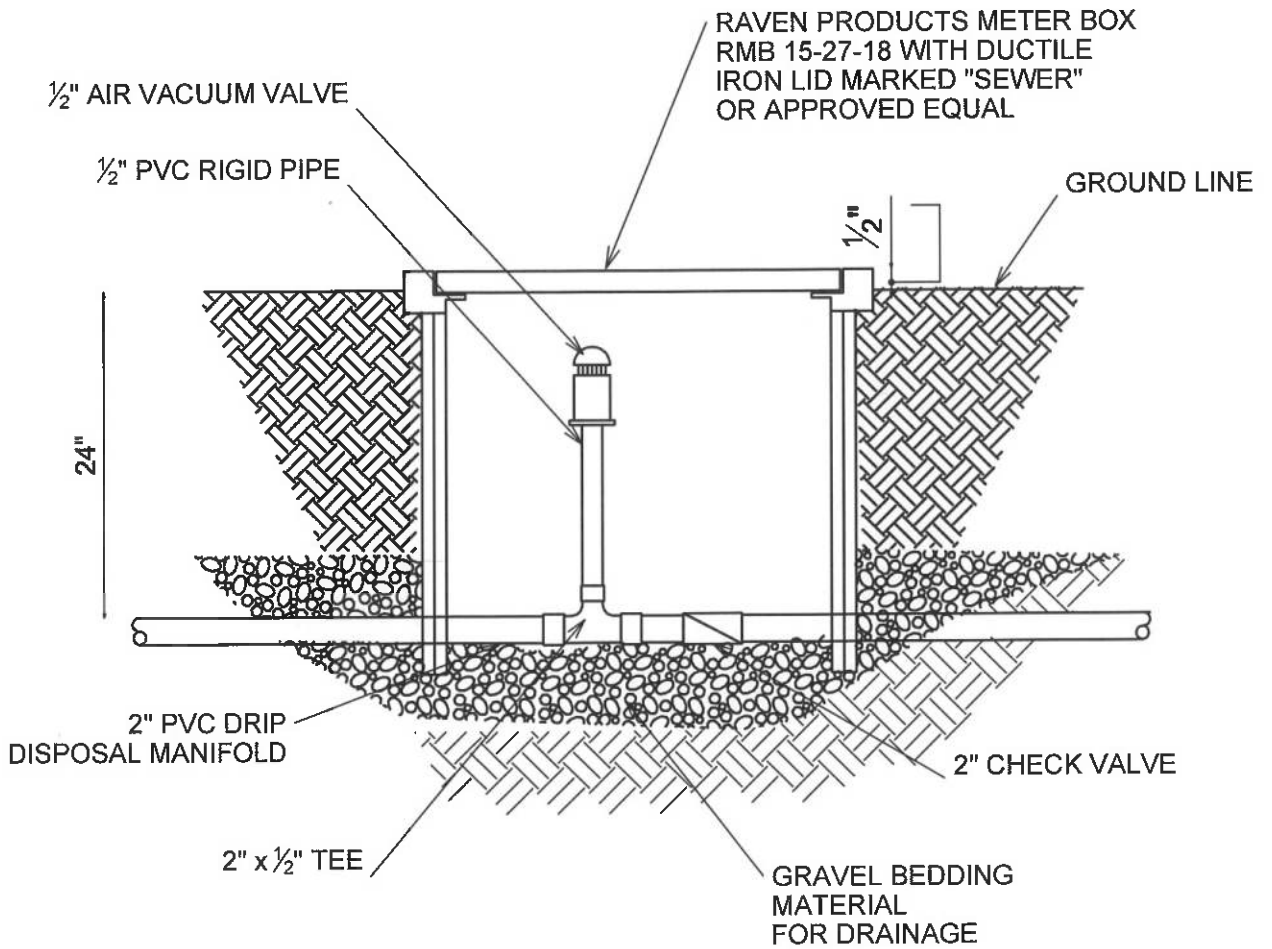

RETURN LINE AIR RELEASE AND CHECK VALVE ASSEMBLY

NOT TO SCALE

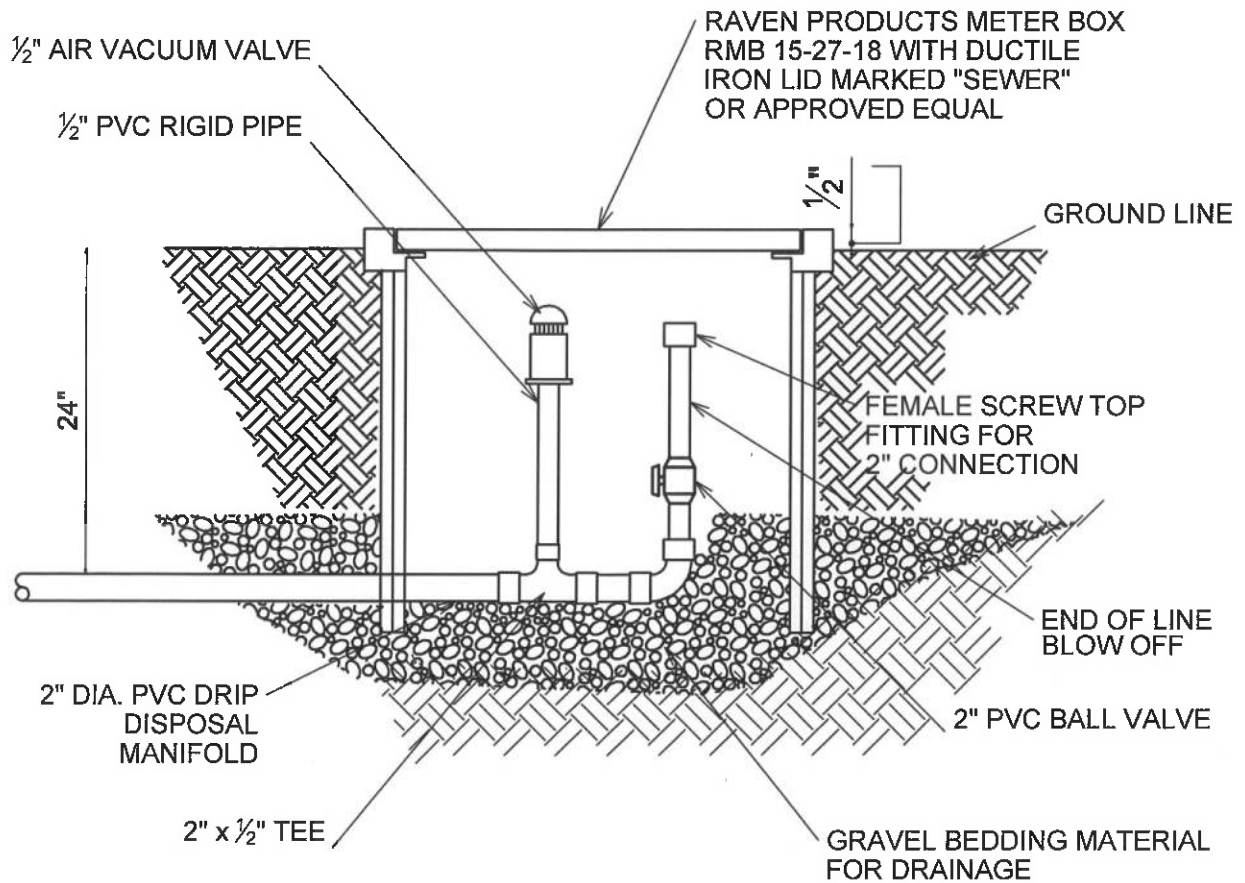

END OF SUPPLY LINE DRIP DISPOSAL AIR RELEASE VALVE AND BLOW-OFF ASSEMBLY

NOT TO SCALE

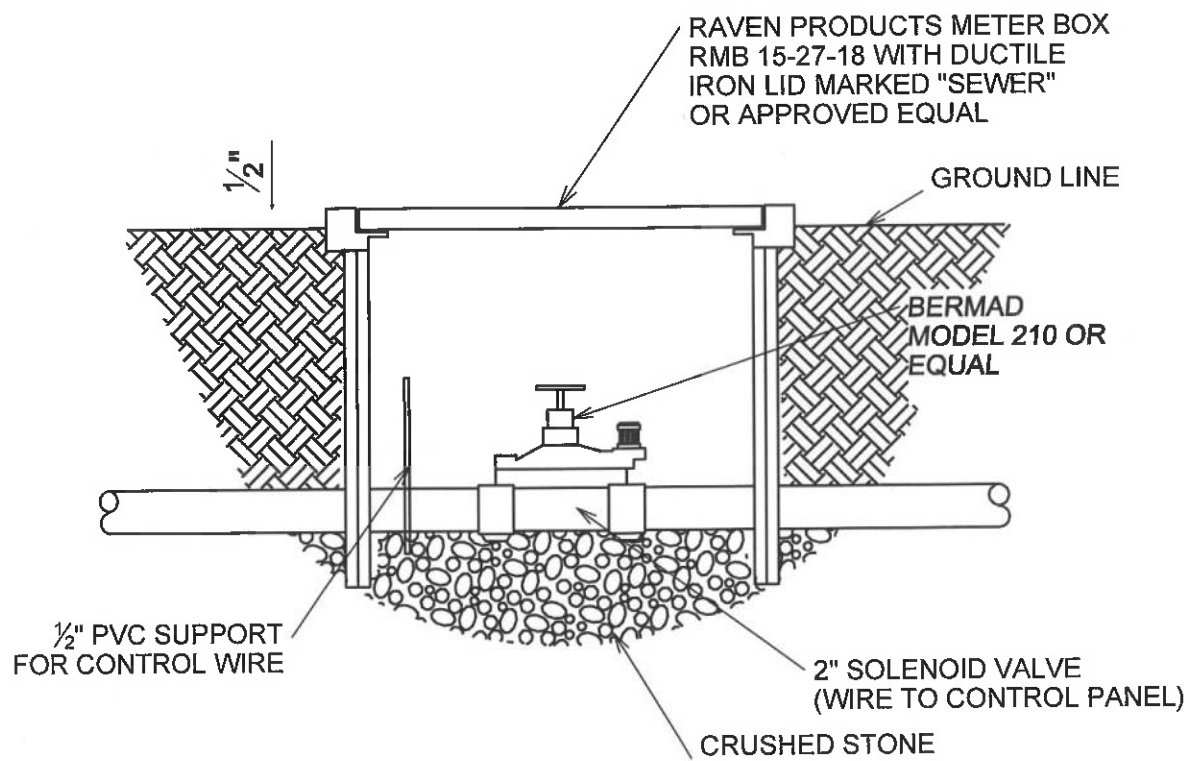

ELECTRIC SOLENOID VALVE

NOT TO SCALE

1. EXCAVATE TRENCH MINIMUM 4" DEPTH X WIDTH OF BALE
2. PLACE AND STAKE STRAW BALES
3. WEDGE LOOSE STRAW BETWEEN BALES
4. BACKFILL AND COMPACT THE EXCAVATED SOIL AGAINST STRAW BALES

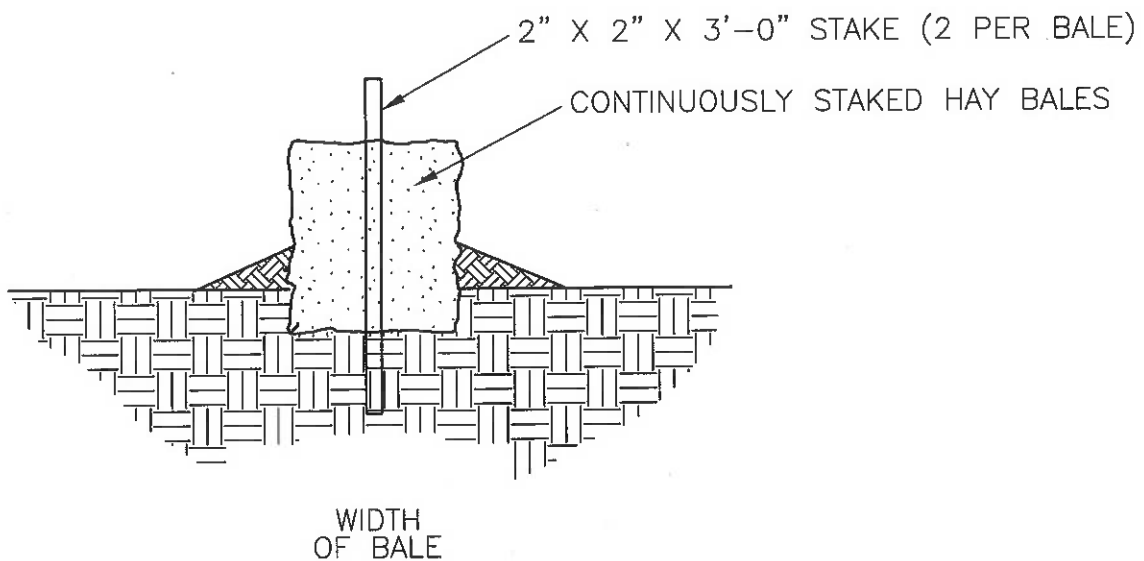

EROSION / SILTATION BARRIER

NOT TO SCALE

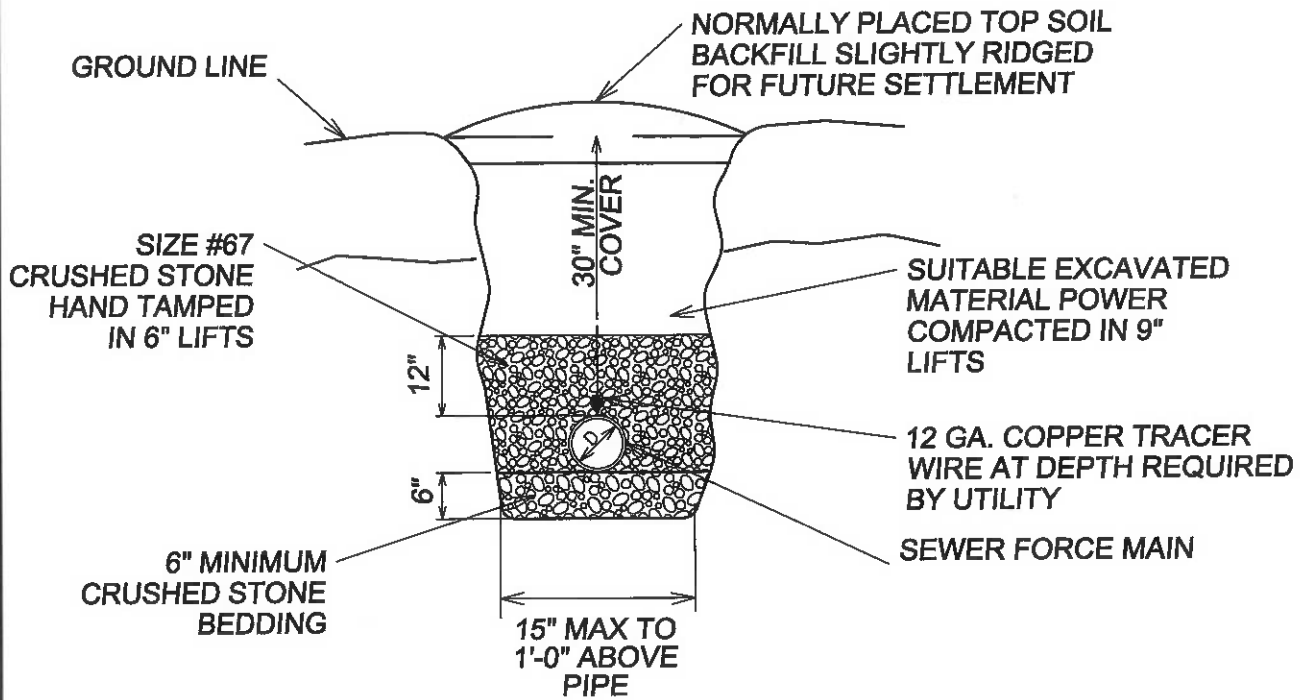

NON-TRAFFIC AREAS

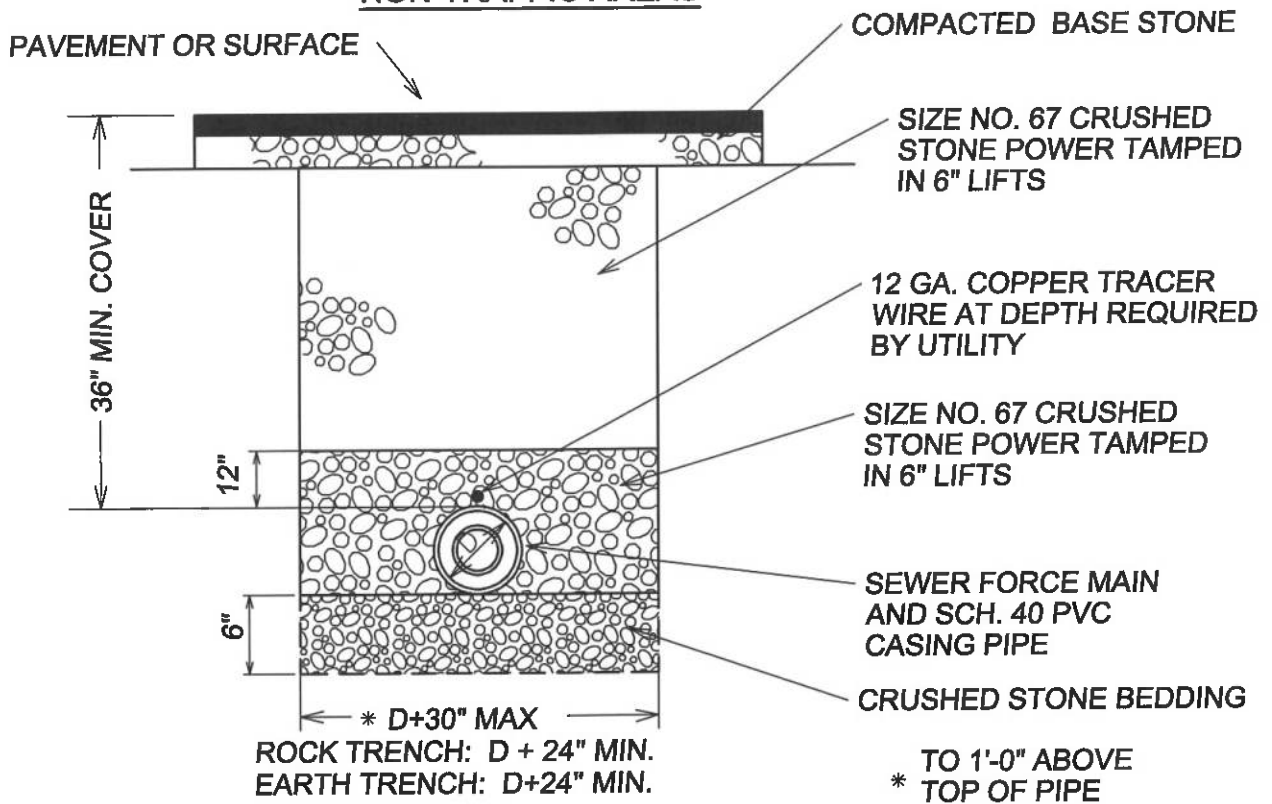

NOTE:
WHEN CASING IS REQUIRED, THE PIPE DIAMETER AND MINIMUM COVER SHALL REFER TO THE CASING DIAMETER.

TRAFFIC AREAS

EARTH TRENCH AND ROCK TRENCH

COLLECTION PIPING TRENCH DETAILS

NOT TO SCALE

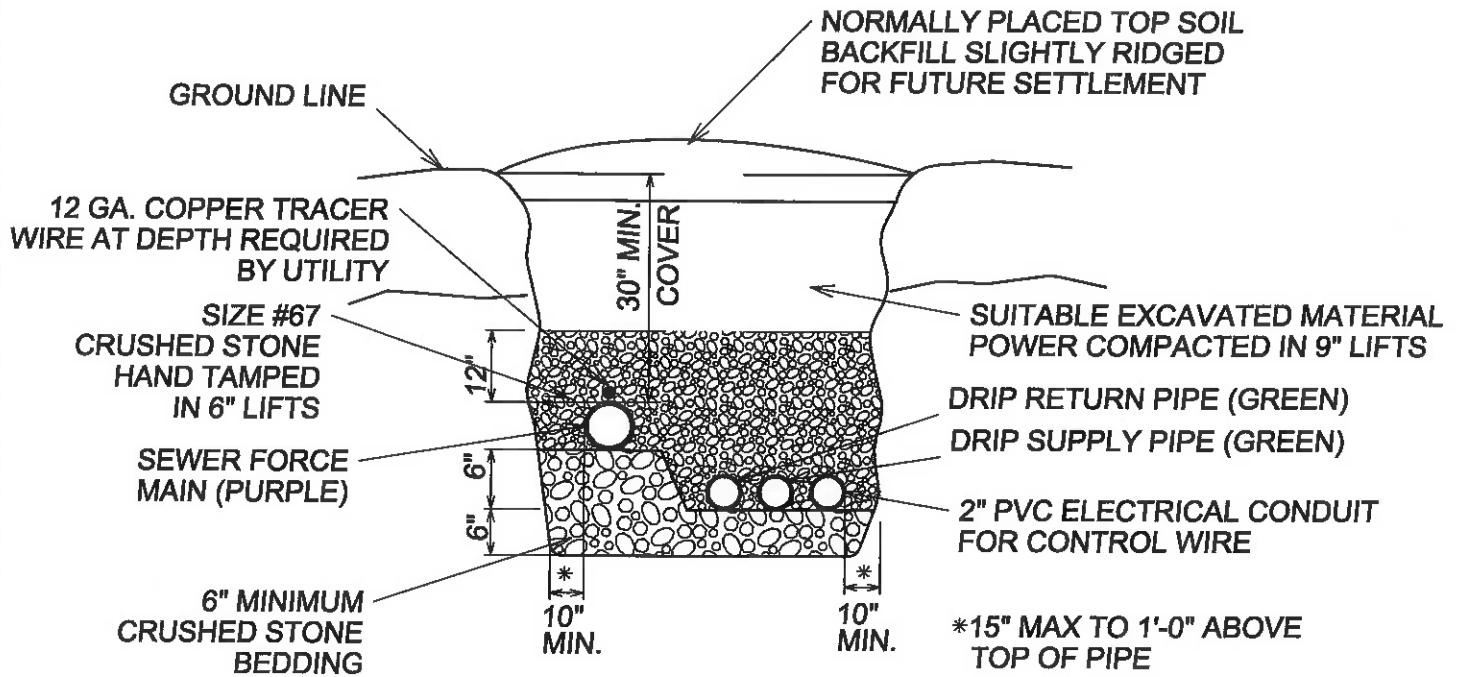

NON-TRAFFIC AREAS

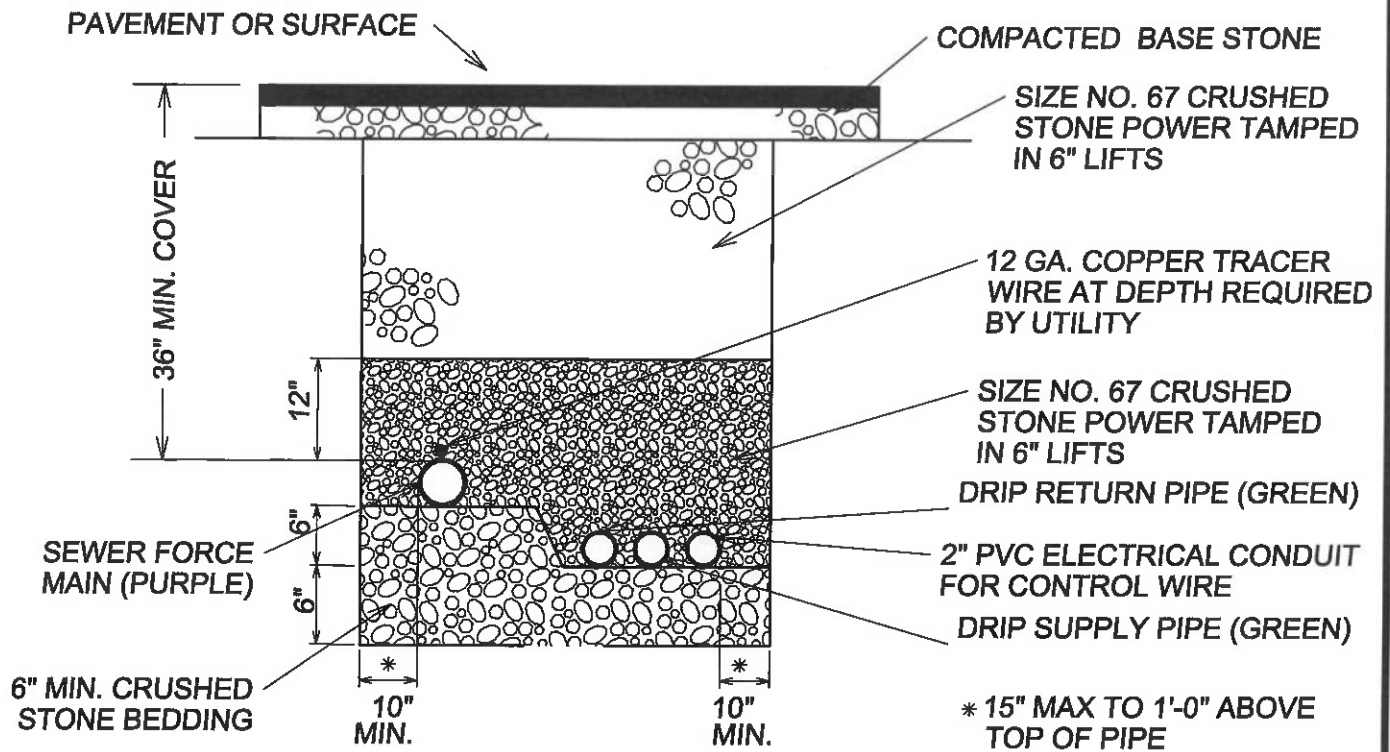

NOTE:
WHEN CASING IS REQUIRED, THE PIPE DIAMETER AND
MINIMUM COVER SHALL REFER TO THE CASING DIAMETER.

TRAFFIC AREAS

EARTH TRENCH AND ROCK TRENCH

**COLLECTION PIPING
JOINT TRENCH DETAILS**

NOT TO SCALE

NOTE:

ALL ELECTRICAL CORDS TO BE CONTINUOUS TO CONTROL PANEL

12" DIA. PVC INSPECTION PORT w/ WATER TIGHT POLYPROPYLENE LID (BURIED)

24" DIA. RIBBED PVC RISER WITH FIBERGLASS GASKETED LID WITH STAINLESS STEEL BOLTS (ATTACH TO RISER ADAPTER RING WITH EPOXY CEMENT)(EACH END)

CONDUIT GAS SEAL

3/4" CONDUITS TO CONTROL PANEL AT HOUSE - 1 PER WIRE

SLOPE GROUND AWAY FROM RISERS

WATERTIGHT FLEXIBLE PIPE BOOT (TYP)

4" INLET TEE (SCH 40 PVC)

3"

18"

3"

HIGH LEVEL ALARM - PUMP ON/OFF

3.5"

3.5"

4" TEE

3"

D (MIN. DEPTH)

BAFFLE WALL

3"

3"

FLOW

4" OF COMPACTED CRUSHER-RUN BEDDING

APPROVED 25000 GALLON SEPTIC TANK - WATER TIGHT PRECAST CONCRETE, PLASTIC OR OTHER APPROVED MATERIAL

STEPROS "BIOTUBE" PUMP VAULT (MODEL HFSCV45MF12)

STERPROS DISCHARGE ASSEMBLY (MODEL DA05-SCV-PEX)

DRAIN PORT w/ FLAP CHECK

1" ORENCO DISCHARGE ASSEMBLY (PVC PIPE & HOSE, BALL VALVE, BALL CHECK, ANTI-SIPHON (1/8" HOLE), UNION FLOW CONTROLLER) DRILL

RISER ADAPTER RING (CAST IN PLACE)

FLEXIBLE HOSE (12" LENGTH)

1" EFFLUENT DISCHARGE

LEVEL CONTROL FLOAT ASSEMBLY

FLOW INDUCER

VAULT INLET PORTS

DUPLEX EFFLUENT PUMP STA RITE PENTAIR PUMP 0.5HP, STEP PUMP 10

FILTER CARTRIDGE

24" DIA. RIBBED PVC RISER WITH FIBERGLASS GASKETED LID WITH STAINLESS STEEL BOLTS (ATTACH TO RISER ADAPTER RING WITH EPOXY CEMENT)(EACH END)

12" DIA. PVC INSPECTION PORT

2-20" DIA. TANK OPENING w/24" DIA. PVC RISER OVER PUMP VAULT

20" DIA. TANK OPENING w/24" DIA. PVC RISER

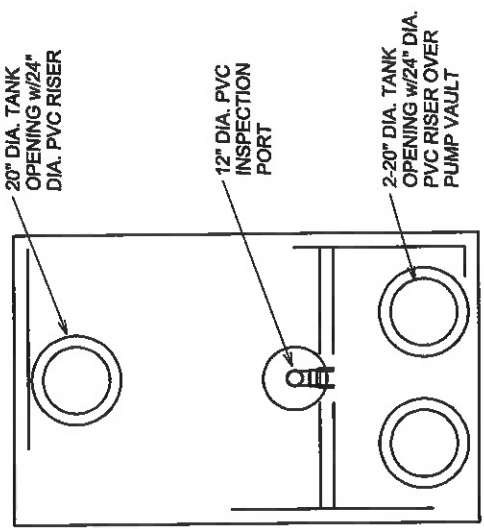

PLAN

SECTION

1,500 GALLON STEP TANK
NOT TO SCALE

Adenus Panel
(Model AT-SF1-ETM)

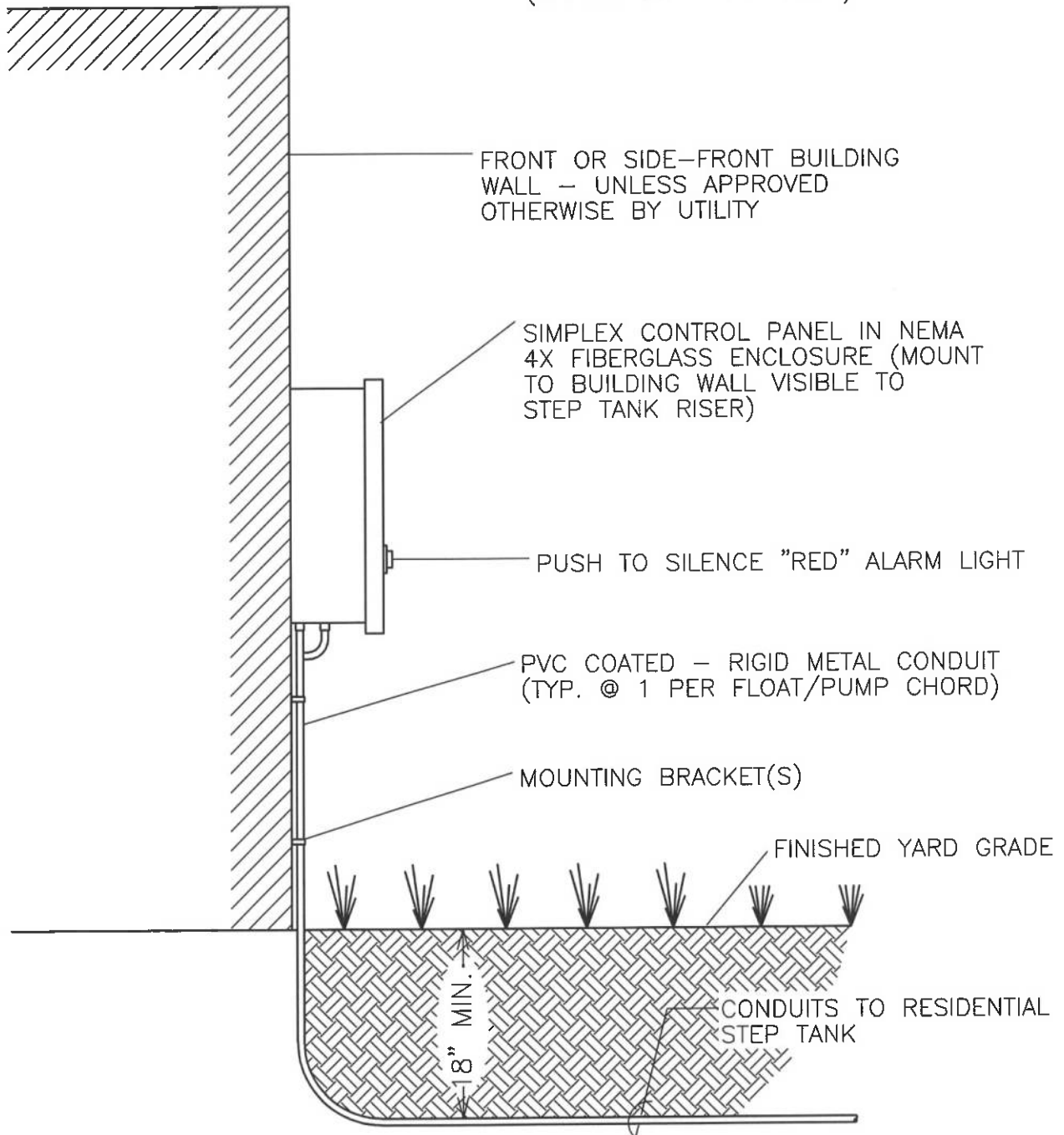

RESIDENTIAL CONTROL PANEL

NOT TO SCALE

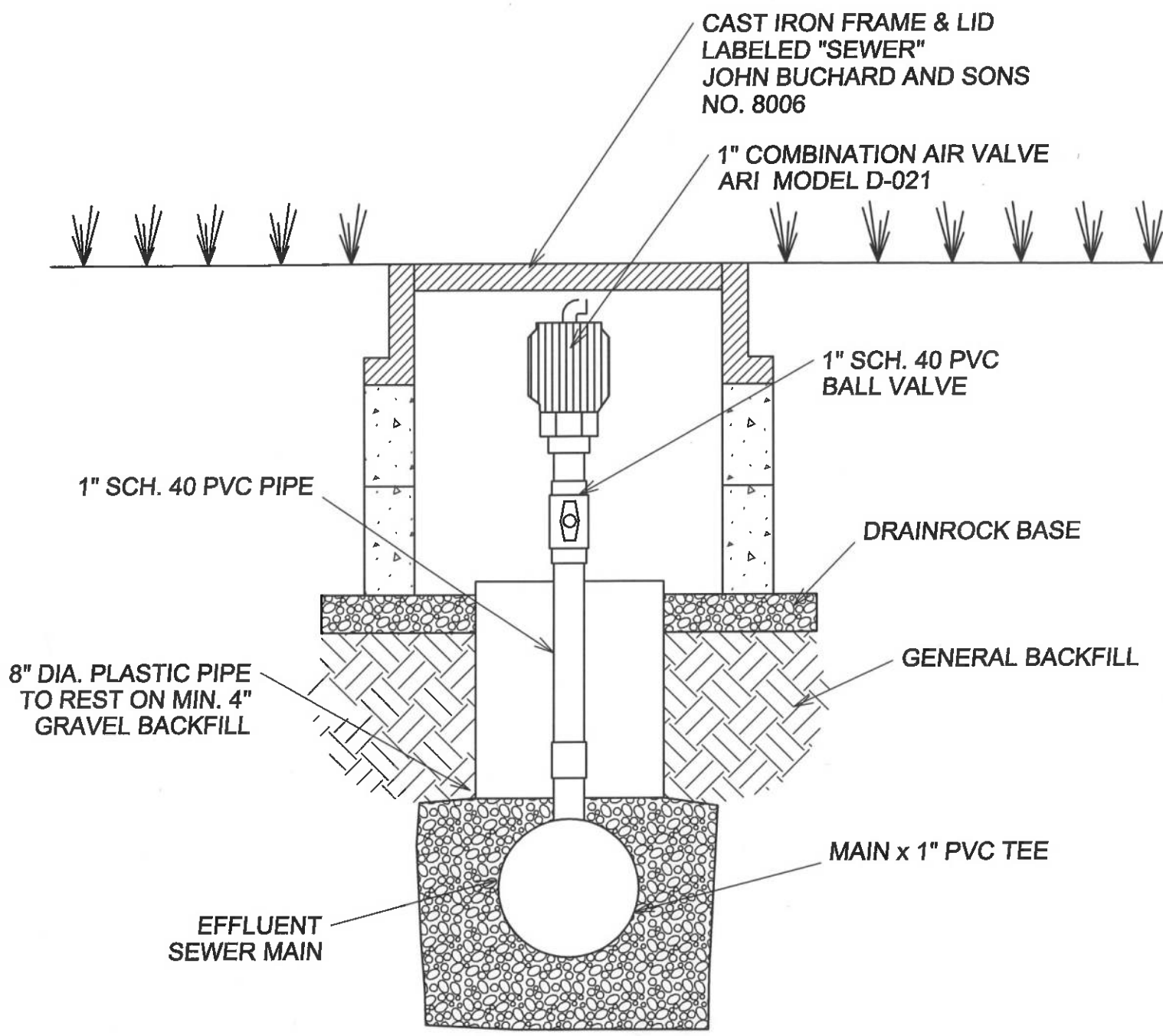

AIR RELEASE VALVE ASSEMBLY
 NOT TO SCALE (IF REQUIRED)

CAST IRON FRAME & LID
LABELED "SEWER"
JOHN BUCHARD AND SONS
NO. 8006

TRACER WIRE RUNS UP OUTSIDE
PRECAST BOX SECTION AND UNDER
FRAME, LOOPED AND BACK TO
FORM A CONTINUOUS RUN OF WIRE

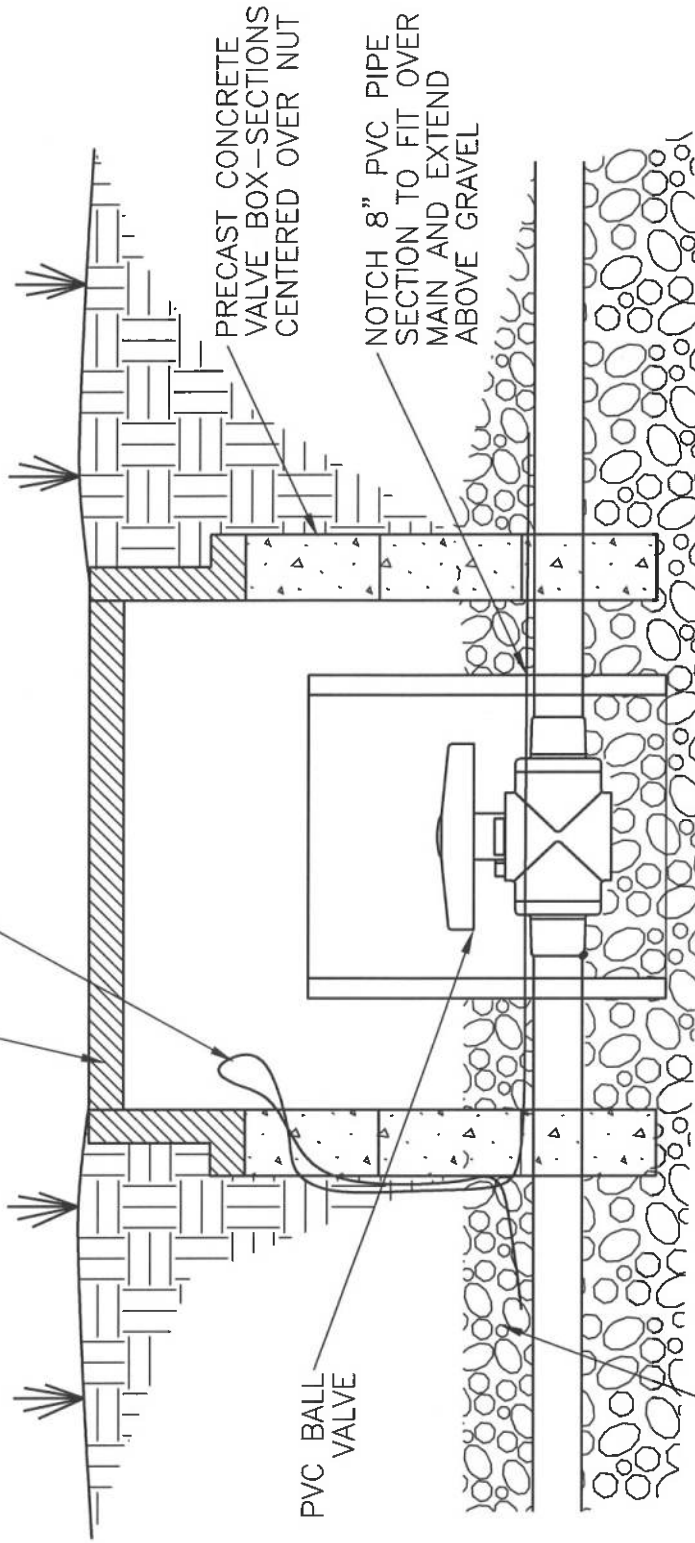

PRECAST CONCRETE
VALVE BOX-SECTIONS
CENTERED OVER NUT

NOTCH 8" PVC PIPE
SECTION TO FIT OVER
MAIN AND EXTEND
ABOVE GRAVEL

PVC BALL
VALVE

CRUSHED
STONE
BACKFILL

LINE VALVE - OUTSIDE PAVEMENT

NOT TO SCALE